

YZF-R6 2023
KIT MANUAL

GYTR[®]
GENUINE YAMAHA TECHNOLOGY RACING
PERFORMANCE PRODUCTS

Introduction

- This manual is intended for persons with knowledge and experience of motorcycles. Please refer to the YZF-R6 service manual, which shall be published from YAMAHA MOTOR CO. LTD., for information on part assembly and maintenance.
- The design of the YZF-R6 racing kit is based on YZF-R6, according to FIM racing rules, but that does not mean the kit conforms to all competitions. When used in races, riders must mount the YZF-R6 racing kit at their own discretion after checking the rules of competition issued by the sponsor.

About Warranty

- Please understand that these parts are not covered by warranty.
- The Manufacturer does not take any responsibility for problems caused by these parts.

Request

- These kit parts are intended exclusively for racing purposes. You are strictly requested not to use them on public roads.
- The specifications and usage methods of these kit parts along with the contents of this manual are subject to change without notice for improvement.

Parts List Symbols

- The star mark (*) means that the part is included in the kit set and is a genuine Yamaha part. Therefore, you can easily purchase the part at any Yamaha part dealer when necessary.
- The circle mark (°) means that although the part is included in the kit set it can also be purchased individually.

	No.	PART No.	PART NAME	Q'TY	REMARKS
°	1	4C8-11181-70	GASKET, CYLINDER HEAD 1	3	t=0.30mm
*	2	5VY-11351-00	GASKET, CYLINDER 1	3	
*	3	4C8-11603-00	PISTON RING SET	12	
	4	5VY-1165A-01	BOLT, CONNECTING ROD SPECIAL	24	
*				24	

Symbol Marks

Particularly important information is distinguished in this manual by the following notations.



This is the safety alert symbol. It is used to alert you to potential personal injury hazards. Obey all safety messages that follow this symbol to avoid possible injury or death.



A WARNING indicates a hazardous situation which, if not avoided, could result in death or serious injury.



A NOTICE indicates special precautions that must be taken to avoid damage to the vehicle or other property.



A TIP provides key information to make procedures easier or clearer.

CONTENTS

1 Engine Specifications	1
2 Kit Parts.....	2
2-1 Electric parts.....	2
1. Wire Harness Set (BN6-F2590-70).....	2
2. ECU Set (BN6-8591A-71,BN6-8591A-A2, BN6-8591A-G0,BN6-8591A-B1)....	11
3. Cable Interface (2CR-8533A-70).....	14
4. CCU COMP.(2KS-85800-72)	16
2-2 Engine Parts.....	21
5. Maintenance Set (2C0-MAINT-71)	21
6. Spark Plug Set (5FL-R045Q-70, 13S-R373A-70).....	22
7. Head Gasket	23
8. Piston Set (13S-116A0-70).....	24
9. Connecting Rod Set (13S-1165B-70).....	24
10. Crankshaft (2C0-11411-70)	24
11. Cam Shaft and Cam Sprocket.....	25
12. Valve Spring Set (2C0-A2110-70)	26
13. Oil Pump (2C0-13300-70)	28
14. Throttle Body Clamp Assembly (2C0-1351A-70).....	28
15. Air Funnel Set (BN6-1440B-70) for SS.....	29
16. Air Funnel Set (BN6-1440B-80) for STK	31
17. AIS Plug Set (13S-A4890-70).....	35
18. Clutch Spring Set (2C0-A6330-70)	37
19. Friction Plate Set (2C0-A6321-70).....	38
20. Slipper Clutch Setting Set (4B1-A6377-70).....	39
21. Transmission Gear	42
22. Mission Maintenance Set (2C0-A7000-70)	46
23. Drive Sprocket.....	49
24. Sprocket Nut Set (2C0-A7463-70).....	50
2-3 Vehicle Accessories	51
25. Oil Catch Tank Set (2C0-C1707-81)	51
26. Rear Shock Spring	52
27. Front Fork Spring	53
28. Seat Cushion (13S-24713-70).....	55
29. Seat Pad (B3L-27741-70).....	55
30. Front Spare Wheel Assembly (BN6-25100-70)	56
31. Rear Spare Wheel Assembly (BN6-25300-70)	57
32. Tube Guide (2CR-26243-70)	58
3 Tightening Torque List.....	59
4 YZF-R6 Wiring Diagram	70

1 Engine Specifications

Spec		SS	STK	STD
Displacement		599cm ³	599cm ³	599cm ³
Bore/Stroke		67.0 × 42.5 mm	67.0 × 42.5 mm	67.0 × 42.5 mm
Maximum engine speed (limiter controlled speed)		16000 rpm	16000 rpm	15800 rpm
Compression ratio (recommended value)		14.5:1 (Depend of head-gasket thickness and cylinder head surface grinding)	13.7:1 (Depending on the thickness of the head gasket)	13.2:1
Valve timing (event angle)	INT.	110°	105°	105°
	EXT.	115°	110°	110°
Squish height	INT.	0.65-0.75mm	0.65-0.75mm	0.65-0.75mm
	EXT.	0.95-1.00mm	0.95-1.00mm	0.95-1.00mm
Clearance between valve and piston (minimum)	INT.	1.05 mm (ATDC 12°)	1.05 mm (ATDC 12°)	1.15 mm (ATDC 12°)
	EXT.	1.62 mm (BTDC 12°)	1.62 mm (BTDC 12°)	1.80 mm (BTDC 12°)
valve (tappet) clearance	INT.	0.12 - 0.19 mm	0.12 - 0.19 mm	0.12 - 0.19 mm
	EXT.	0.16 - 0.27 mm	0.16 - 0.23 mm	0.16 - 0.23 mm

2 KIT PARTS

2-1 Electric parts

1. Wire Harness Set(BN6-F2590-70)

Parts List

	No.	PART No.	PART NAME	Q'TY	REMARKS
	1	BN6-82590-70	WIRE HARNESS ASSY.	1	
○	2	BN6-82386-70	WIRE, SUB-LEAD for TH INJECTOR	1	TH INJECTOR
○	3	BN6-83553-70	WIRE, LEAD for METER	1	METER
○	4	2CR-8231Y-70	WIRE, LEAD for FUEL PUMP	1	FUEL PUMP
*	5	5GF-83976-00	SW., HANDLE 1	1	Switch for TAIL LIGHT
	6	BN6-2128A-70	BRKT., REGULATOR 1	1	
*	7	90480-13003	GROMMET	1	
*	8	90560-06201	SPACER	2	
*	9	90111-06051	BOLT, HEX. SOCKET BUTTON	4	
*	10	92907-06200	WASHER, PLAIN	1	

R6EN20181106

This wire harness is trim weighted from the STD part by reducing the lighting wiring accessories.

NOTICE

- To ensure the power to run the vehicle, do not remove the AC generator. Use on the battery alone will make the vehicle unable to run in a short time.
- The wire harness will not function if it is not assembled with the ECU (BN6-8591A-70, 71, A0, A1, A2, G0, B0, B1) of the kit.
- The combination of this wire harness and ECU can only be used with '17 to '22 models.
- When using the KIT ECU for the first time, perform base map writing using the YMS in advance. Before starting assembly, remove the coupler of the main switch.
- Be sure to connect the Hydraulic unit assy. to the wire harness. The ABS does not function when using the KIT ECU, but every electronic control does not work without the connection. Also, change the installation position of the Hydraulic unit assy. by following the instructions on following pages.

Installation

1. Remove the STD wire harness from the vehicle.
2. Remove the STD rectifier/regulator (on the left side of the radiator) from the vehicle.

3. As illustrated, install the removed rectifier/regulator using the provided bracket regulator, etc.

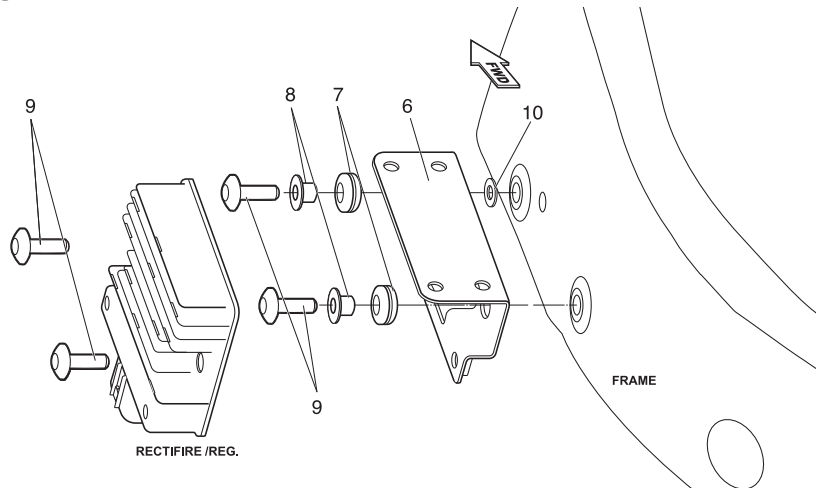

4. Remove the Hydraulic unit assy. from the right side of the vehicle.

5. Remove the EXUP motor located under the seat.

6. To install the Hydraulic unit assy. to the position where the EXUP motor was removed, you need to perform processing operation. Refer to the following images to perform processing operation.

TIP

To install the Hydraulic unit assy., you need to perform processing operation to create the installation space.

Before processing

After processing

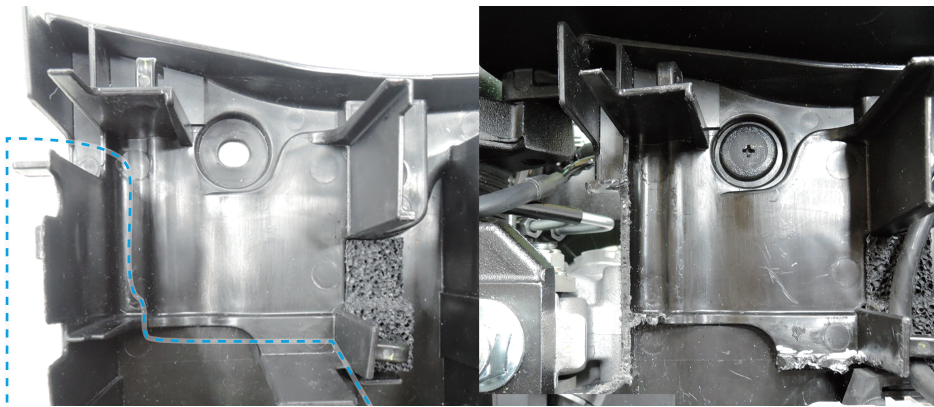

Before processing

After processing

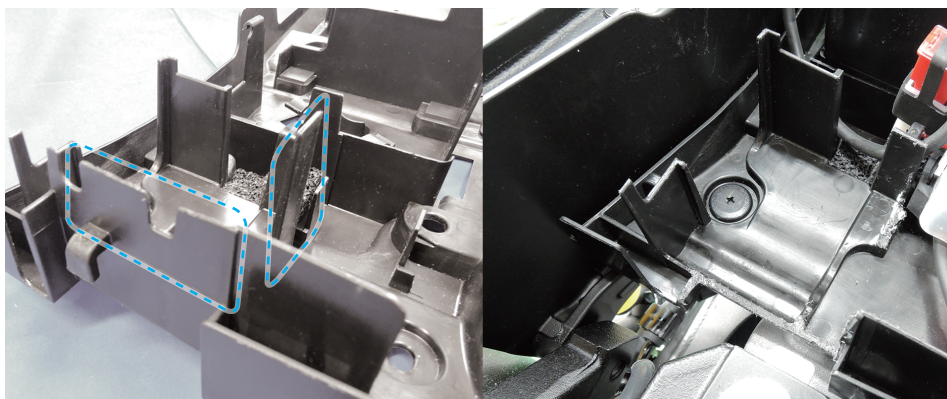

7. Prepare buffer such as sponges and rubber seats.
Set the buffer at the installation space created in the Step 6 and cut the buffer to the size of the Hydraulic unit assy.

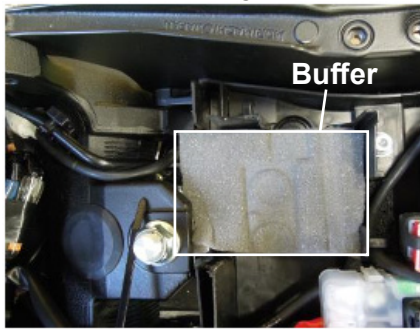

8. Set the Hydraulic unit assy. on the buffer.

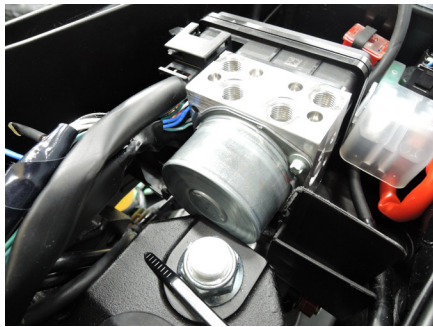
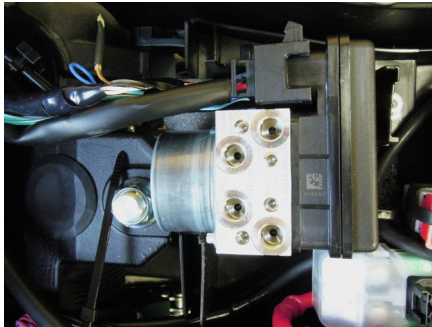

TIP

Fix the Hydraulic unit assy. with the rubber band located at the position indicated by an arrow in the following image.

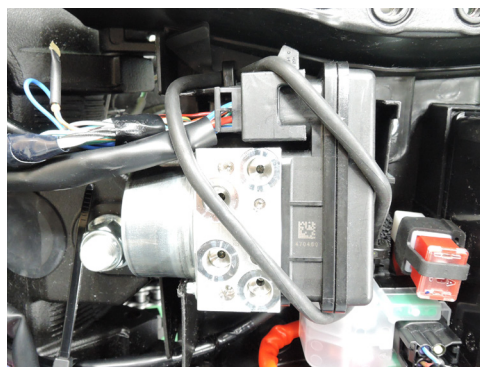
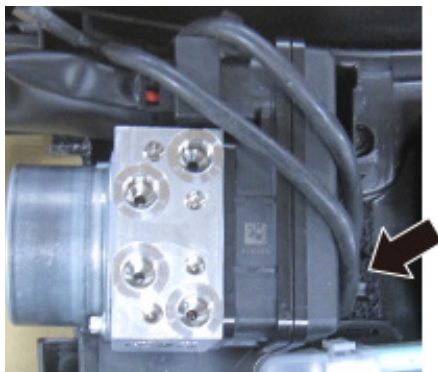

9. Assemble the wire harness to the chassis referring to the following materials.

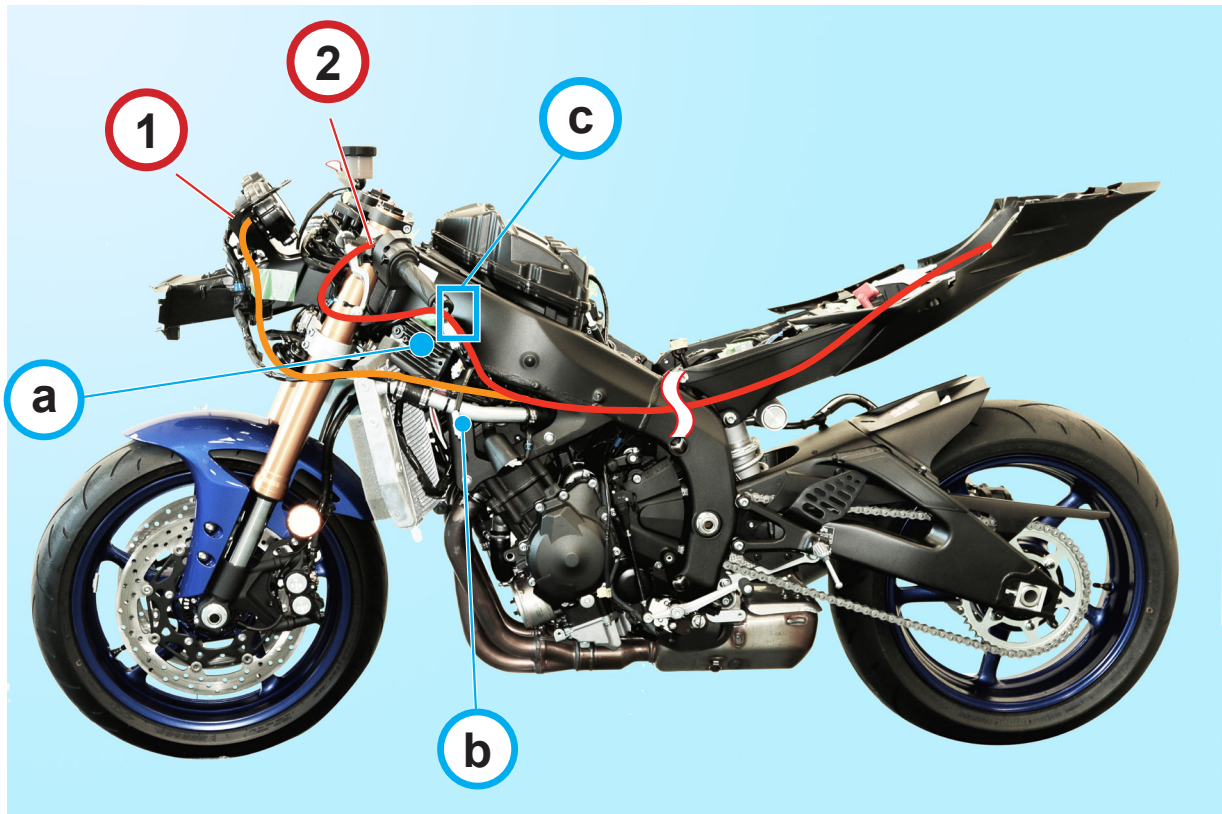

Connect each wire lead to the following parts.

1	BN6-83553-70
	WIRE,LEAD for METER
	METER
	AIR TEMP SENSOR
	PRESSURE SENSOR

2	BN6-82590-70
	WIRESHARNES ASSY.
	MAIN SW
	SW.HANDLE L 1/2
	POWER SUPPLY 2

Check the position of the following parts.

a RECTIFIRE/REGULATOR

b SELECT SW.

TIP

c Fix the harness that will be connected to SW.HANDLE L 1/2, etc. to 6 BLKT.,REGULATOR 1 using cable ties.

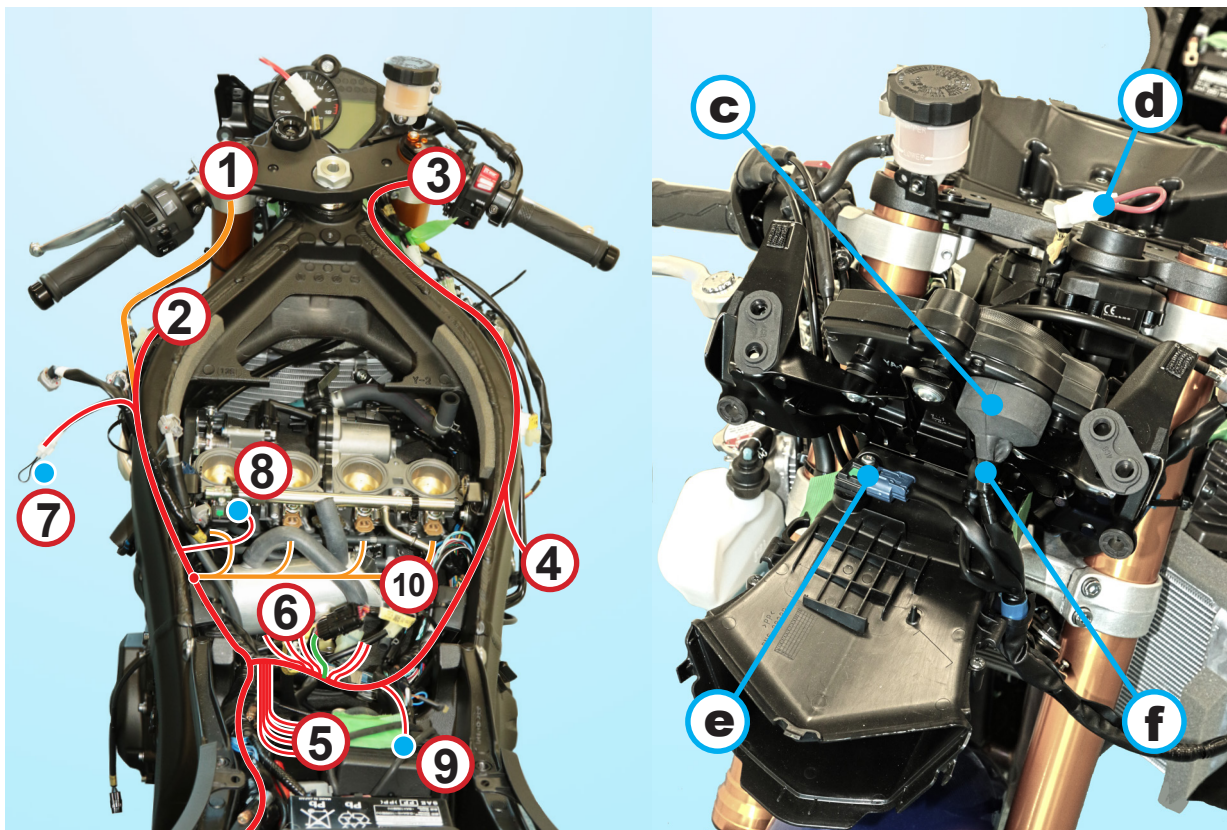

Connect each wire lead to the following parts.

BN6-83553-70 WIRE, LEAD for METER	
1	METER
	AIR TEMP SENSOR
	PRESSURE SENSOR

BN6-82590-70 WIRE HARNESS ASSY.	
2	MAIN SW
	SW. HANDLE L 1/2
	POWER SUPPLY 2
3	APS
	THROTTLE MOTOR
	TPS
	PC/IF
	FR WHEEL SENSOR
4	SW HANDLE R 2/3
	WATER TEMP SENSOR
5	RR WHEEL SENSOR
	GEAR PO. SENSOR
	VI MOTOR
	NEUTRAL SW.
6	LIGHT SW.
	OIL SW.
	SHIFT SW.
	CRANK SHAFT SENSOR
	WIRE SUBLEAD 1/4
	WIRE, LEAD for FUEL PUMP

BN6-82590-70 WIRE HARNESS ASSY.	
7	SELECT SW.
8	PRESSURE SENSOR
9	ABS ECU (Hydraulic unit assy.)

BN6-82386-70 WIRE, SUB-LEAD for TH INJECTOR	
10	TH INJECTOR

Check the position of the following parts.

- c** METER
- d** MAIN SW.
- e** AIR TEMP SENSOR
- f** PRESSURE SENSOR

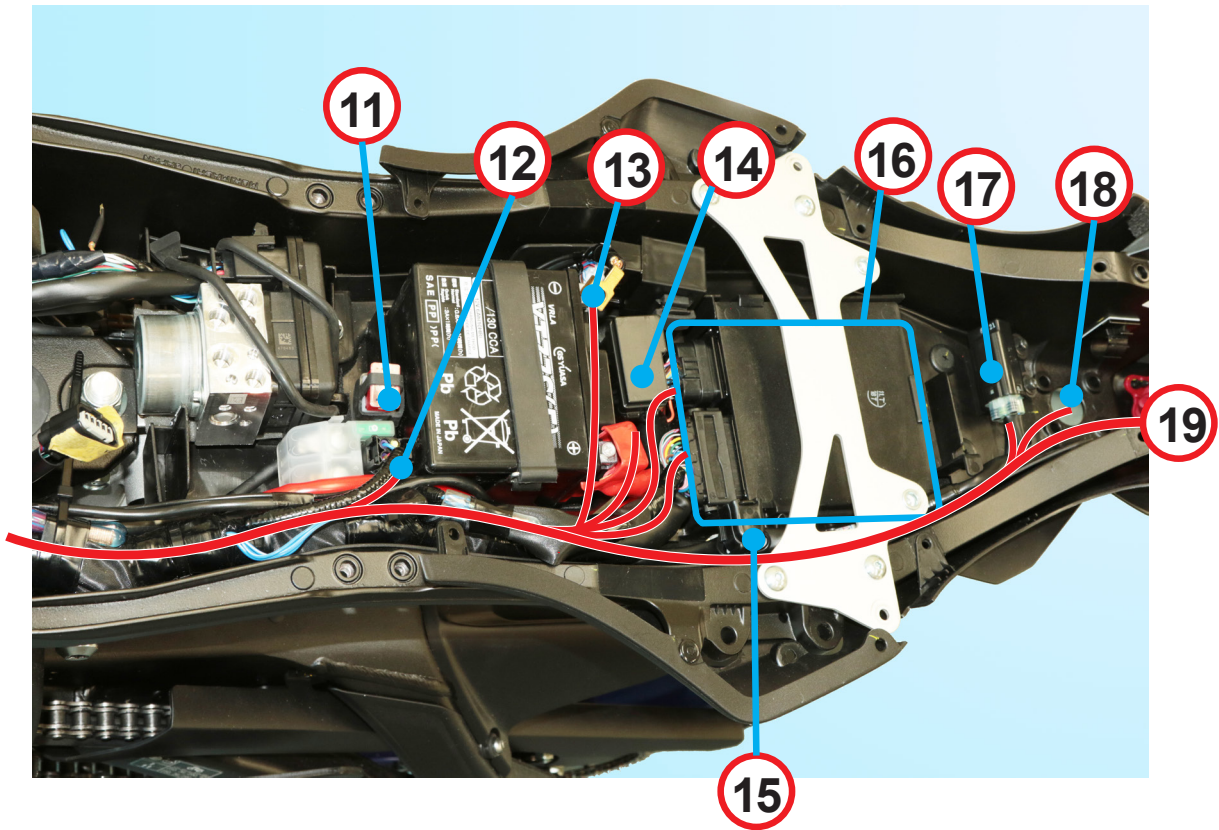

Connect each wire lead to the following parts.

BN6-82590-70 WIREHARNSS ASSY.	
11	MAIN FUSE
12	ST.RELAY 1
13	RELAY ASSY.
14	FUSE BOX 1
15	SERVICE TOOL
16	ECU
17	LEAN ANGLE SENSOR
18	POWER SUPPLY
19	TAIL LIGHT

BN6-82590-70 WIRE HARNESS ASSY. Details

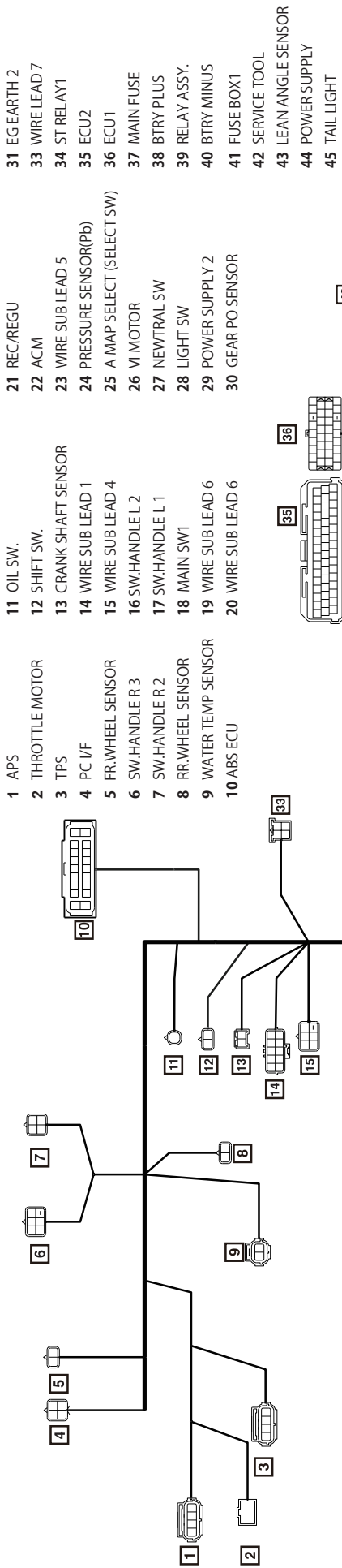

BN6-82386-70 WIRE, SUB-LEAD for TH INJECTOR Details

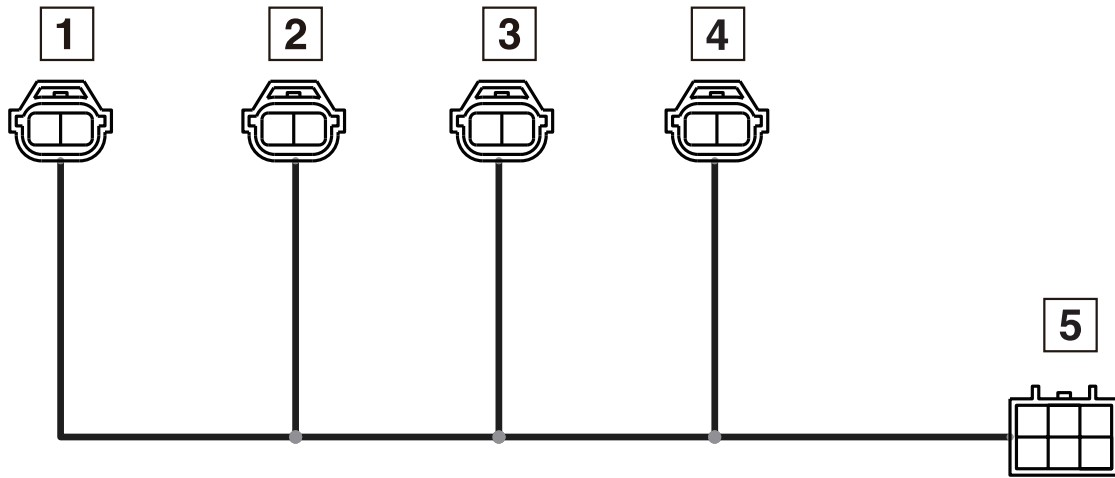

- 1 INJECTOR_41
- 2 INJECTOR_31
- 3 INJECTOR_21
- 4 INJECTOR_11
- 5 MAIN_HARNES

BN6-83553-70 WIRE, LEAD for METER Details

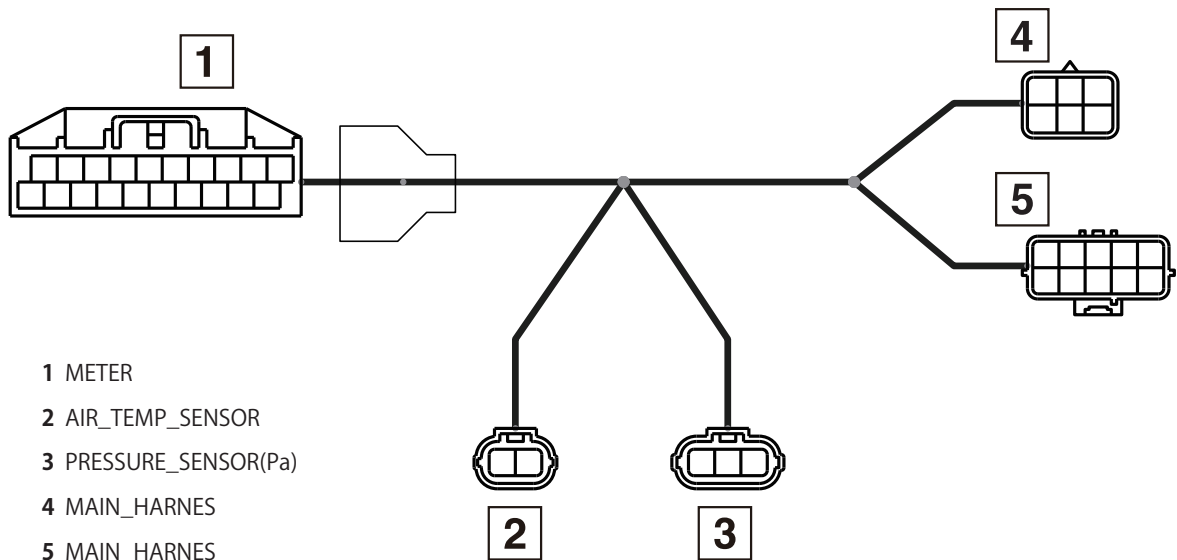

- 1 METER
- 2 AIR_TEMP_SENSOR
- 3 PRESSURE_SENSOR(Pa)
- 4 MAIN_HARNES
- 5 MAIN_HARNES

Name and function of each switch

- The following figures explain the names and functions of the switches located at the right and left sides of handle.

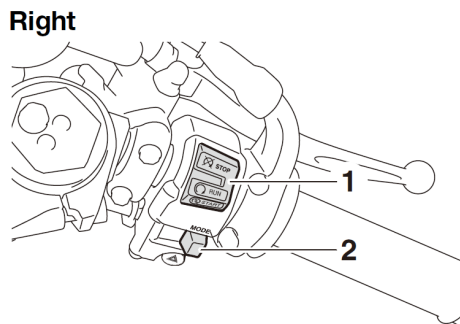

1 Starter switch, Engine stop switch

Same as the STD. For details, refer to the owner's manual of the STD.

2 Mode switch

Same as the STD. For details, refer to the owner's manual of the STD.

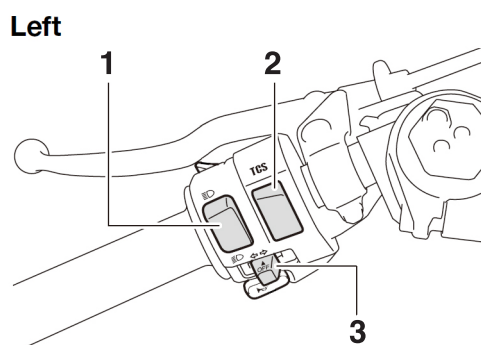

1 Map select switch

 : Map1

 : Map2

2 TCS switch

For details, refer to the owner's manual of the STD.

For TCS on/off operation, refer to the service manual.

3 Pit road limiter

"""": Switch to any direction to enable the limiter function.

"OFF" : Press to disable the limiter function.

2. ECU Set (BN6-8591A-71, BN6-8591A-A2, BN6-8591A-G0, BN6-8591A-B1)

Parts List (BN6-8591A-71)

No.	PART No.	PART NAME	Q'TY	REMARKS
1	BN6-8591A-71	ECU for SS Following WSS rule	1	
2	B3L-2818Y-74	CD	1	YMS SOFT & MANUAL

The ECU in this set has base data (R6-19_BaseData_00_SS.ycz) written for SS.

Parts List (BN6-8591A-A2)

No.	PART No.	PART NAME	Q'TY	REMARKS
1	BN6-8591A-A2	ECU for STK	1	
2	B3L-2818Y-74	CD	1	YMS SOFT & MANUAL

The ECU in this set has base data (R6-22_BaseData_A0-STD_STK.ycz) written for STK.

Parts List (BN6-8591A-G0)

No.	PART No.	PART NAME	Q'TY	REMARKS
1	BN6-8591A-G0	ECU for STK	1	
2	B3L-2818Y-74	CD	1	YMS SOFT & MANUAL

The ECU in this set has base data (R6-19_BaseData_A0_STK.ycz) written for STK.

BN6-8591A-G0 has the same specifications as BN6-8591A-A1.

Parts List (BN6-8591A-B1)

No.	PART No.	PART NAME	Q'TY	REMARKS
1	BN6-8591A-B1	ECU for STK(TCS/LIF off)	1	
2	B3L-2818Y-74	CD	1	YMS SOFT & MANUAL

The ECU in this set has base data (R6-22_BaseData_B0-STD_STK.ycz) written for STK(TCS/LIF off).

R6EN20220215rev

- Use of this set and a wire harness included in the kit enables regulation (or setting) of fuel injection and ignition timing, etc.
- For details as to how to regulate (or set) fuel injection and ignition timings, etc., refer to the manual in the CD-ROM that comes with the set.
- BN6-8591A-71 The ECU contains basic control data for SS (super sports).
BN6-8591A-71 The ECU can not use the TCS / LIF function.
- BN6-8591A-A2/G0 The ECU contains basic control data for STK (stock sports).
BN6-8591A-A2/G0 The ECU can use the TCS / LIF function.
- BN6-8591A-B1 The ECU contains basic control data for STK (stock sports).
BN6-8591A-B1 The ECU can not use the TCS / LIF function.

<Setting-up Details>

SS specification: Kit cam shaft and *Recommended muffler

STK specification: *Recommended muffler

* **Recommended muffler**

Made by Akrapovic (For details of the specification, please access the website.)

Web <https://www.akrapovic.com/en/intro?returnUrl=%2F>

R6EN20200602

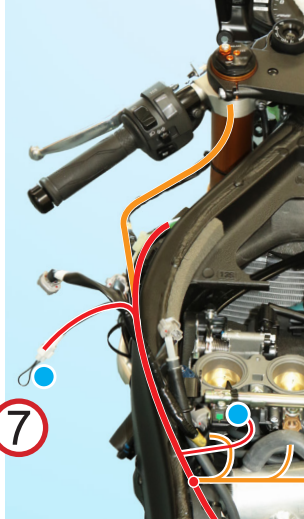

BN6-82590-70 WIREHARNSS ASSY.
7

You can switch the mode between STD air funnel mode and KIT STK air funnel (BN6-1440B-80) mode by inserting and removing the 2-pole coupler (7) of the kit harness.
When the coupler is connected, it becomes KIT STK air funnel (BN6-1440B-80) mode.
When the coupler is disconnected, it becomes STD air funnel mode.
When shipped, the coupler is connected.

Do not use the camshaft, valve spring, ECU, air funnel and wire harness except for the following combinations.

PARTS COMBINATION TABLE

MODEL	CAMSHAFT(IN)	CAMSHAFT(EX)	VALVE SPRING	AIR FUNNEL SET	ECU	WIRE HARNESS SET
2008	2C0-12171-71	2C0-12181-71	2C0-A2110-70	2C0-8591A-80	2C0-8591A-80 2C0-8591A-90 2C0-8591A-91	13S-F82590-70 13S-F82590-71
2009				MGC-A300908-00		
2010	2C0-12171-72					
2011	2C0-12171-73			MGC-A300908-10 (MGC-A300912-00)	2C0-8591A-92 2C0-8591A-93 2C0-8591A-94	
2012						
2013						
2014						
2015						
2016						

FOR SS

MODEL	CAMSHAFT(IN)	CAMSHAFT(EX)	VALVE SPRING	AIR FUNNEL SET	ECU	WIRE HARNESS SET
2017 2018 2019 2020 2021 2022 2023	2C0-12171-73	2C0-12181-71	2C0-A2110-70	BN6-1440B-70 MGC-A300908-10 with MGC-A300912-00	BN6-8591A-70 BN6-8591A-71	BN6-F2590-70

FOR STK

MODEL	SHAFT CAM1 (INT)	SHAFT CAM 2 (EXT)	VALVE SPRING	AIR FUNNEL SET	ECU	WIRE HARNESS SET
2017 2018 2019 2020 2021 2022 2023	-	-	-	Use with standard air funnel.	BN6-8591A-A0 BN6-8591A-A1 BN6-8591A-A2 BN6-8591A-G0 BN6-8591A-B0 BN6-8591A-B1	BN6-F2590-70
2017 2018 2019 2020 2021 2022 2023	-	-	-	BN6-1440B-80	BN6-8591A-A2 BN6-8591A-B1	

*No other combination is allowed to use.

3. Cable Interface (2CR-8533A-70)

Parts List

No.	PART No.	PART NAME	Q'TY	REMARKS
1	2CR-8533A-70	CABLE, INTERFACE	1	USB
2	2CR-N81CD-71-1	CD	1	USB driver Windows 10 supported

R6EN20191201

- This cable connects the kit wire harness to the personal computer on which YEC FI Matching System (YMS) is installed.
- Please see the YMS manual for instructions on how to use YMS.
- When connecting the cable to the PC for the first time, it is necessary to install the USB driver. Refer to the USB Driver Installation Manual provided on the CD for details on how to install the USB driver.

Self-Diagnosis Functions

- To check the following codes, connect an OBD tool (commercially available) to the vehicle using the genuine Yamaha part "90890-03249 OBD/GST LEADWIRE KIT".
You can purchase "90890-03249 OBD/GST LEADWIRE KIT" at any Yamaha part dealer.

DTC CODE	DTC English name / check item	
P0916	Gear Shift Position Circuit Low	Open circuit / short circuit
P0917	Gear Shift Position Circuit High	Supply fault
P0340	Camshaft Position Sensor "A" Circuit Bank 1 or Single Sensor	Disabled
P0335	Crankshaft Position Sensor "A" Circuit	Disabled
P0107	Manifold Absolute Pressure/Barometric Pressure Sensor Circuit Low	Ground fault
P0108	Manifold Absolute Pressure/Barometric Pressure Sensor Circuit High	Open circuit / supply fault
P0122	Throttle/Pedal Position Sensor/Switch "A" Circuit Low	Ground fault
P0123	Throttle/Pedal Position Sensor/Switch "A" Circuit High	Open circuit / supply fault
P0222	Throttle/Pedal Position Sensor/Switch "B" Circuit Low	Ground fault
P0223	Throttle/Pedal Position Sensor/Switch "B" Circuit High	Open circuit / supply fault
P2135	Throttle/Pedal Position Sensor/Switch "A" / "B" Voltage Correlation	Deviation fault
P0069	Manifold Absolute Pressure - Barometric Pressure Correlation	Incompatibility
P1004	Manifold Absolute Pressure - Cylinder Identification MAP Correlation	Incompatibility
P0117	Engine Coolant Temperature Sensor 1 Circuit Low	Ground fault
P0118	Engine Coolant Temperature Sensor 1 Circuit High	Open circuit / supply fault
P0112	Intake Air Temperature Sensor 1 Circuit Low Bank 1	Ground fault
P0113	Intake Air Temperature Sensor 1 Circuit High Bank 1	Open circuit / supply fault
P2228	Barometric Pressure Sensor "A" Circuit Low	Ground fault
P2229	Barometric Pressure Sensor "A" Circuit High	Open circuit / supply fault
P0351	Ignition Coil "A" Primary Control Circuit/Open	Disabled
P0352	Ignition Coil "B" Primary Control Circuit/Open	Disabled
P0353	Ignition Coil "C" Primary Control Circuit/Open	Disabled
P0354	Ignition Coil "D" Primary Control Circuit/Open	Disabled
P0201	Cylinder 1 Injector "A" Circuit	Disabled
P0500	Vehicle Speed Sensor "A" Circuit	No signals
P0657	Actuator Supply Voltage "A" circuit/Open	Abnormity
P062F	Internal Control Module EEPROM Error	Writing error
P1602	Internal Control Module Shutoff Circuit	Abnormity
P0560	System Voltage	Abnormity
P0601	Internal Control Module Memory Checksum Error	Checksum error
P0606	Control Module Processor	Communication fault between CPUs Sub CPU ROM/RAM abnormality Main CPU operation abnormality CC cancel condition incompatibility TP1 amplification value abnormality
P2122	Throttle/Pedal Position Sensor/Switch "D" Circuit Low	Open circuit / ground fault
P2123	Throttle/Pedal Position Sensor/Switch "D" Circuit High	Supply fault
P2127	Throttle/Pedal Position Sensor/Switch "E" Circuit Low	Ground fault
P2128	Throttle/Pedal Position Sensor/Switch "E" Circuit High	Open circuit / supply fault
P2138	Throttle/Pedal Position Sensor/Switch "D" / "E" Voltage Correlation	Deviation fault
P0638	Throttle Actuator Control Range/Performance Bank 1	Disabled
P2158	Vehicle Speed Sensor "B" Circuit	No signals
P1E70	YDT event	Implementation judgment

4. CCU COMP. (2KS-85800-72)

The CCU (Communication control unit) facilitates checking or settings of the vehicle information, and enhances rider's relationship with the vehicle.

The CCU COMP. consists of the CCU ASSY. and GPS unit.

Download the application onto the tablet before use.

The CCU of RACING KIT PARTS is equipped with the general-purpose analog voltage (0 to 5 V) interface.

For information about the standard features, refer to the OWNER'S MANUAL for the vehicle or the explanation of the store application in addition to this manual.

R6180501Rev



Parts List

No.	PART No.	PART NAME	Q'TY	REMARKS
1	2KS-85810-72	CCU ASSY.	1	dedicated software embedded
*	2	2KS-88107-00	1	GPS unit
	3	2KS-85721-71	1	Sub-harness
		Application		Download from App Store/Google Play Store

R6EN20191201

Components

CCU ASSY.

(dedicated software embedded)



Sub-harness



GPS unit



Application

Download from App Store/Google Play Store.

TIP

The functions of the CCU unit

- Data logging (GPS positioning information, vehicle information, analog voltage)
- Line passing detection
- Wireless LAN main unit (IEEE 802.11b/g/n)

Preparation

- Install the units to the vehicle.

TIP

The gray and black cable is for AIN-1 (analog Ch1), and the purple and black cable is for AIN-2 (analog Ch2).

TIP

Since the eight-digit number (S/N:) on the CCU unit will be used as the password for wireless LAN connection between the tablet and CCU, be sure to write down the number.



TIP

When using it for the first time, check if the GPS icon lights up on the meter before riding.

(It may take about 10 minutes for GPS positioning even in an outdoor location.)

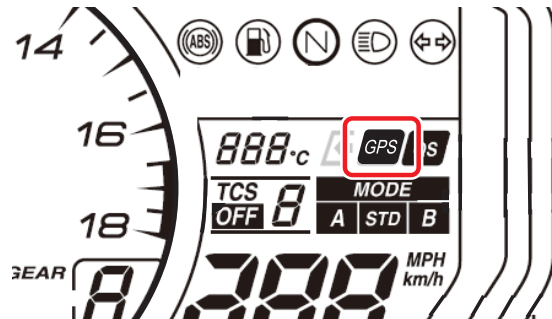

NOTICE

If GPS positioning is not available, it will affect functioning of logging.

- Download the application onto the tablet.

TIP

For Android, visit Google Play Store and download "Y-TRAC" and "CCU Config".



For iOS, visit App Store and download "Y-TRAC". (Y-TRAC is equipped with the CCU Config feature.)



In this manual, iOS version screens are used as examples.

Usage

	Operations on the tablet	Application to be used	Network to be connected
Before riding	Draw a circuit record line on the map. (See Fig. 1.)	CCU Config (Y-TRAC for iOS version)	Internet
	Transfer the record line to the CCU.	CCU Config (Y-TRAC for iOS version)	CCU
	Set the logging mode of the CCU to "Track". (See Fig. 2.)	CCU Config (Y-TRAC for iOS version)	CCU
While riding			
After riding	Download the logging data from the CCU.	Y-TRAC	CCU
	Display the logging data (with map).	Y-TRAC	Internet

(Fig. 1.)

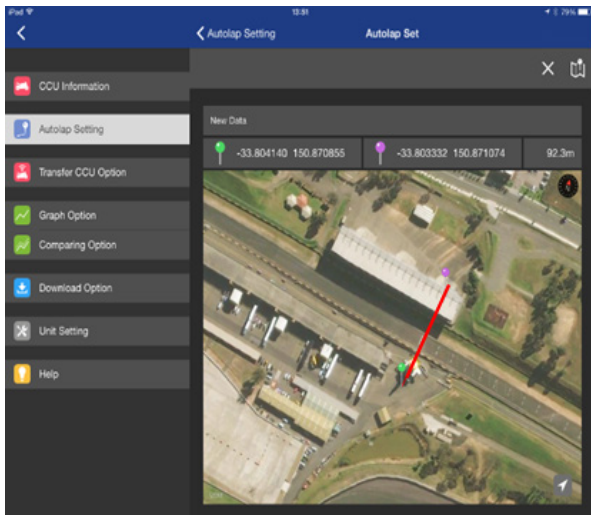

(Fig. 2.)

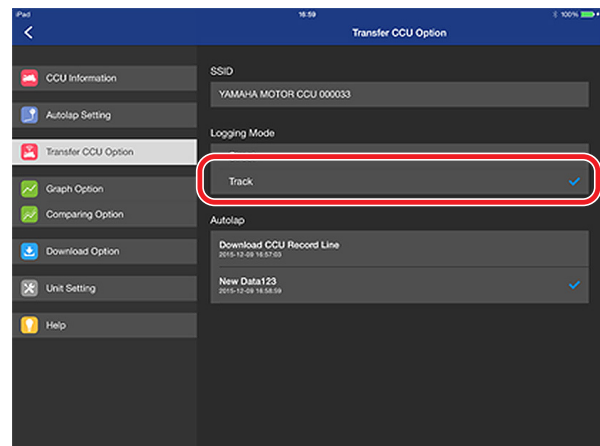

TIP

When connecting the tablet to the network, select CCU (when communicating with the CCU) or Internet (when displaying the map) according to the use.

Connecting to the CCU

Connecting to the CCU		Label on the CCU (See Fig.3.)
Network name (SSID)	YAMAHA MOTOR CCU ddeeff	MAC: aa-bb-cc-dd-ee-ff
Password	12345678	S/N: 12345678

(Fig. 3.)



TIP

When viewing logging data, analog Ch is not displayed by Y-TRAC default setting. To display it, tap Graph Setting in the Graph Option mode.

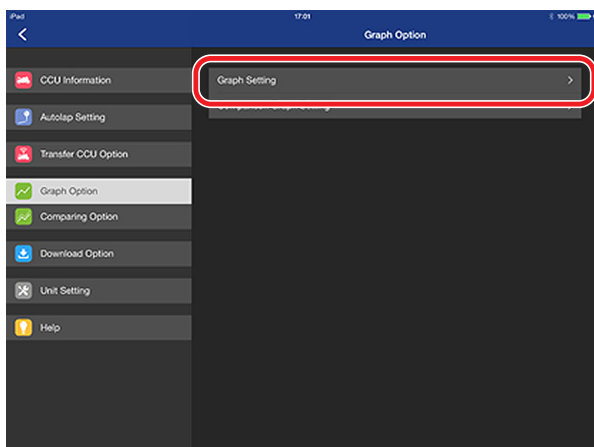

On the screen, tap AIN-1 or AIN-2 to display the arbitrary CH.

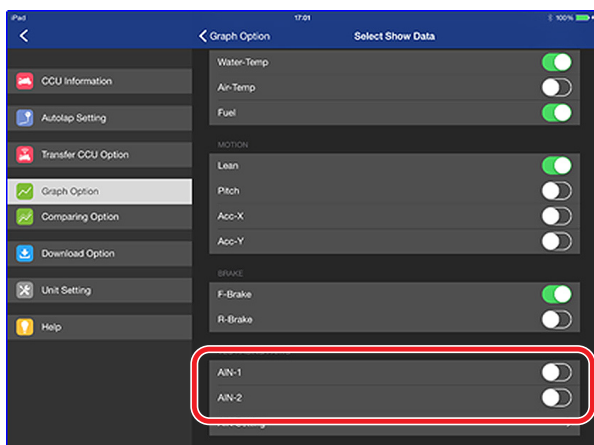

In the analog display mode, the voltage is indicated by level (0 to 5) by default. The display value can be changed according to the specification of the installed sensor. To change the display value, tap AIN Setting.

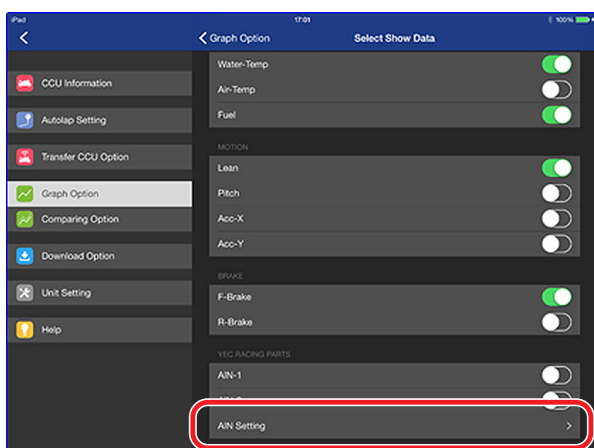

<Example 1>

When the following is stated in the sensor's manual

"AF value: voltage x 1.6 +10"

Factor **1.6000**

Offset **10.0000**

Min Y-axis **10.00**

Max Y-axis **20.00**

(Min Y-axis and Max Y-axis can be any given values)

<Example 2>

When the following is stated in the sensor's homepage

"Output voltage is three times the λ value."



AF value: output voltage x 14.7 / 3

Factor **4.9000**

Offset **0.0000**

Min Y-axis **10.00**

Max Y-axis **20.00**

(Min Y-axis and Max Y-axis can be any given values)

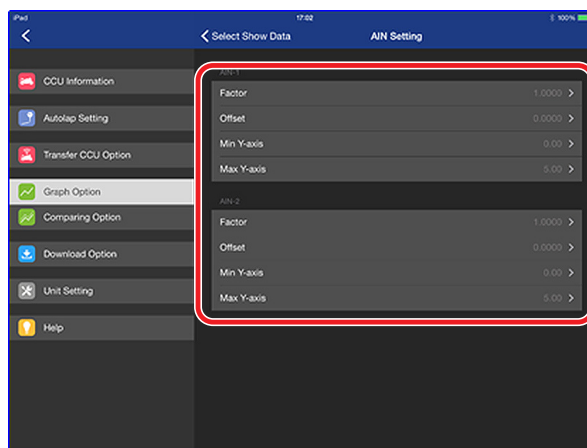

Other usages

Meter setting

To indicate CCU's detection of line passing on the meter, enable the stop watch function on the meter (blink ":" (colon) and "." (period) in the lap time display area).

<Operation procedure>

Short press the SELECT switch and RESET switch simultaneously to start the lap timer. ":" (colon) and "." (period) will blink when the lap timer starts up.

SELECT button

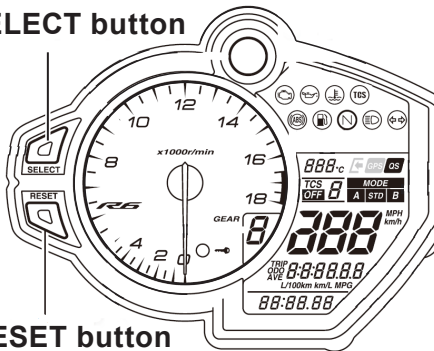

RESET button

R6180501Rev

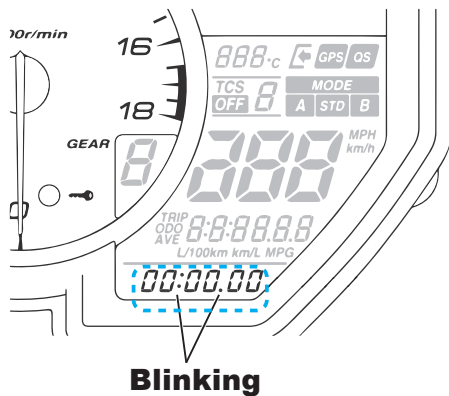

This operation is required each time after the main switch is set to ON.

R6180501Rev

TIP

Regardless of the meter setting, lap data will be recorded in the logging data when line passing is detected.

2-2 Engine Parts

5. Maintenance Set (2C0-MAINT-71)

Parts List

	No.	PART No.	PART NAME	Q'TY	REMARKS
°	1	2C0-11181-76	GASKET, CYLINDER HEAD	3	t=0.45mm
*	2	2C0-11603-00	PISTON RING SET	12	
*	3	93450-16159	CIRCLIP	24	
	4	2C0-1165A-00	BOLT, CONNECTING ROD	24	
*	5	90179-07001	NUT	24	
*	6	4SV-12119-00	SEAL, VALVE STEM OIL	48	
*	7	2C0-12213-00	GASKET, TENSIONER	3	
°	8	2C0-13414-70	GASKET, STRAINER	3	ANTI STICK TYPE
°	9	2C0-15451-70	GASKET, CRANKCASE COVER 1	3	ANTI STICK TYPE
°	10	2C0-15461-70	GASKET, CRANKCASE COVER 2	3	ANTI STICK TYPE
°	11	2C0-15456-70	GSKT., 1	3	ANTI STICK TYPE
*	12	93102-35017	SEAL, OIL	3	FOR DRIVE AXLE
*	13	90151-06024	SCREW, CROSSRECESSED COUNTERSUNK	9	FOR BEARING HOUSING

6. Spark Plug Set (5FL-R045Q-70, 13S-R373A-70)

Parts List

Semi surface discharge Type (5FL-R045Q-70)

No.	PART No.	PART NAME	Q'TY	REMARKS
1	5FL-1119C-70	PLUG, SPARK	4	NGK R0045Q-10

Parts List

Angled ground strap Type (13S-R373A-70)

No.	PART No.	PART NAME	Q'TY	REMARKS
1	13S-1119C-70	PLUG, SPARK	4	NGK R0373A-10

TIP

Since these spark plugs have a copper gasket, caution is needed during installation on the following points.

1. The tightening torque is 12 – 15 N•m (1.2 – 1.5 kgf•m).
2. When not checking the torque, tighten by rotating through 30° after manual tightening in the case of new plugs. When reusing plugs, tighten by rotating through 15°.

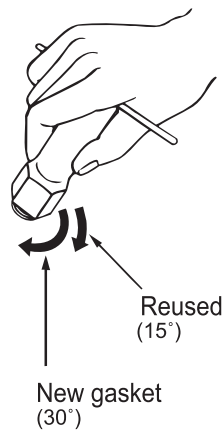

7. Head Gasket

Parts List

No.	PART No.	PART NAME	Q'TY	REMARKS
1	2C0-11181-71	GASKET, CYLINDER HEAD	1	t=0.40mm
2	2C0-11181-76	GASKET, CYLINDER HEAD	1	t=0.45mm
3	2C0-11181-81	GASKET, CYLINDER HEAD	1	t=0.50mm
4	2C0-11181-86	GASKET, CYLINDER HEAD	1	t=0.55mm

*The thickness of a standard part is t=0.60 mm.

These parts are used to adjust the compression ratio for improving performance by selecting a given gasket (thickness).

Be sure to measure the squish height and choose the appropriate gasket so that it meets the recommended height. (Recommended squish height: INT. 0.65-0.75mm EXT. 0.95-1.00mm)

TIP

Squish height means the gap between the flat portion of the piston and the head cylinder.

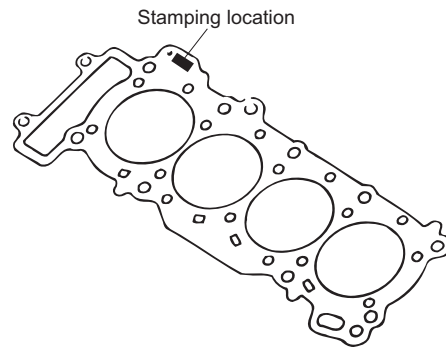

Measuring the volume of the cylinder head combustion chamber

TIP

To obtain the highest performance for race use, the four cylinders should be uniform. If you modify the head cylinder (combustion chamber volume), be sure to measure the combustion chamber volume and do the work based on the measured value.

Measure the volume of the combustion chamber of the cylinder head (commonly called the dome volume) as follows.

Measuring equipment

1. Burette
2. Clear plastic plate
3. Oil (3:1 mixture of torque converter oil and white gasoline)
4. Vaseline (to seal the valve and plastic plate)

Measurement method

1. Tighten a regulation spark plug to the regulation torque in the cylinder head to be measured.
2. Set so that the alignment surface of the combustion chamber is level.
3. Apply a thin coat of Vaseline to the valve face and set the IN and EX valves.
4. Apply a thin coat of Vaseline to the combustion chamber alignment surface and set the plastic plate.
5. Add drops of oil from the burette. The total added amount minus the valve back clearance is the volume of the combustion chamber.

8. Piston Set (13S-116A0-70)

Parts List

	No.	PART No.	PART NAME	Q'TY	REMARKS
*	1	13S-11631-00	PISTON	4	
*	2	2C0-11603-00	PISTON RING SET	4	
*	3	2C0-11633-00	PIN, PISTON	4	
*	4	93450-16159	CIRCLIP	8	

Select four pistons so that the difference in their weights does not exceed 0.5g.

9. Connecting Rod Set (13S-1165B-70)

Parts List

	No.	PART No.	PART NAME	Q'TY	REMARKS
*	1	13S-11650-01	CONN. ROD ASSY	4	

R6EN20181106

Select four connecting rod assemblies so that the difference in their weights does not exceed 2g and combine them so that the small end weights are uniform. (by Yamaha's measuring method)

10. Crankshaft (2C0-11411-70)

Parts List

	No.	PART No.	PART NAME	Q'TY	REMARKS
*	1	2C0-11411-00	CRANKSHAFT	1	

Select a crankshaft with good balance.

11. Cam Shaft and Cam Sprocket

Cam Shaft1 INT (2C0-12171-73)

Parts List

No.	PART No.	PART NAME	Q'TY	REMARKS
1	2C0-12171-73	SHAFT, CAM 1	1	INT

R6EN20181106

Cam Shaft2 EXT(2C0-12181-71)

Parts List

No.	PART No.	PART NAME	Q'TY	REMARKS
2	2C0-12181-71	SHAFT, CAM 2	1	EXT

R6EN20181106

Cam Sprocket1 INT(2C0-12176-80)

Parts List

No.	PART No.	PART NAME	Q'TY	REMARKS
3	2C0-12176-80	SPROCKET, CAM 1	1	INT

R6EN20181106

Cam Sprocket2 EXT(2C0-12177-80)

Parts List

No.	PART No.	PART NAME	Q'TY	REMARKS
4	2C0-12177-80	SPROCKET, CAM 2	1	EXT

R6EN20181106

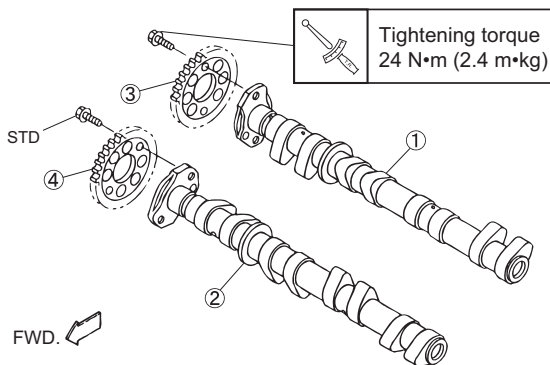

Assembly of Cam Sprocket

By making the assembly holes of the cam sprocket of the racing kit long, the valve timing can be adjusted within the range of -2° to $+6^{\circ}$ (CA) compared with standard timing.



Tightening torque

NOTICE

- When fitting the camshaft, use the cam sprockets of the kit and always set the valve timing to match. If otherwise, no intended performance can be expected and more over, the engine may be damaged.
- When using this camshaft, use the valve spring set 2C0-A2110-70.

Sprocket assembly position at top dead center point of #1 cylinder compression

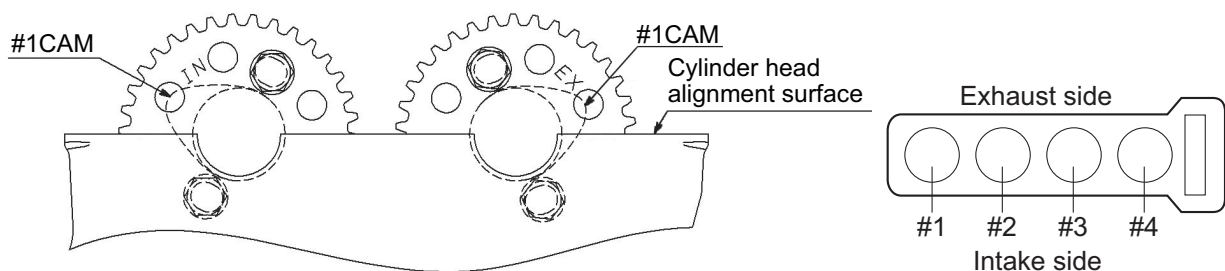

12. Valve Spring Set (2C0-A2110-70)

Parts List

No.	PART No.	PART NAME	Q'TY	REMARKS
1	2C0-12113-70	SPRING,1	8	For 2C0-12171-71 (INT) Identifying color: Light blue
2	2C0-12114-70	SPRING,2	8	For 2C0-12181-71 (EXT) Identifying color: Yellow
3	2C0-12117-70	RET., VALVE SPRING	16	

- This set will be effective in improving the engine performance and durability if it is provided exclusively for the kit cam shaft and used in combination.

NOTICE

When using this valve spring, use the camshafts 2C0-12171-71, 2C0-12171-72, 2C0-12171-73, and 2C0-12181-71.

Do not use the camshaft, valve spring, ECU, air funnel and wire harness except for the following combinations.

PARTS COMBINATION TABLE

MODEL	CAMSHAFT(IN)	CAMSHAFT(EX)	VALVE SPRING	AIR FUNNEL SET	ECU	WIRE HARNESS SET
2008	2C0-12171-71	2C0-12181-71	2C0-A2110-70	2C0-8591A-80	2C0-8591A-80 2C0-8591A-90 2C0-8591A-91	13S-F82590-70 13S-F82590-71
2009				MGC-A300908-00		
2010	2C0-12171-72					
2011	2C0-12171-73			MGC-A300908-10 (MGC-A300912-00)	2C0-8591A-92 2C0-8591A-93 2C0-8591A-94	
2012						
2013						
2014						
2015						
2016						

FOR SS

MODEL	CAMSHAFT(IN)	CAMSHAFT(EX)	VALVE SPRING	AIR FUNNEL SET	ECU	WIRE HARNESS SET
2017 2018 2019 2020 2021 2022 2023	2C0-12171-73	2C0-12181-71	2C0-A2110-70	BN6-1440B-70 MGC-A300908-10 with MGC-A300912-00	BN6-8591A-70 BN6-8591A-71	BN6-F2590-70

FOR STK

MODEL	SHAFT CAM1 (INT)	SHAFT CAM 2 (EXT)	VALVE SPRING	AIR FUNNEL SET	ECU	WIRE HARNESS SET
2017 2018 2019 2020 2021 2022	-	-	-	Use with standard air funnel.	BN6-8591A-A0 BN6-8591A-A1 BN6-8591A-A2 BN6-8591A-G0 BN6-8591A-B0 BN6-8591A-B1	BN6-F2590-70
2017 2018 2019 2020 2021 2022 2023	-	-	-	BN6-1440B-80	BN6-8591A-A2 BN6-8591A-B1	

***No other combination is allowed to use.**

13. Oil Pump (2C0-13300-70)

Parts List

No.	PART No.	PART NAME	Q'TY	REMARKS
1	2C0-13300-70	OIL PUMP ASSY.	1	

- This pump is capable of a larger discharge than the STD counterpart.

14. Throttle Body Clamp Assembly (2C0-1351A-70)

Parts List

No.	PART No.	PART NAME	Q'TY	REMARKS
1	2C0-1351A-70	THROTTLE BODY CLAMP ASSY.	1	

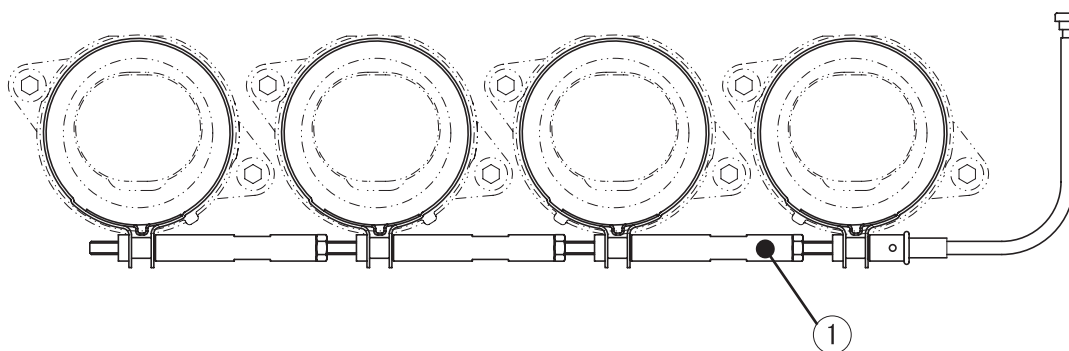

This part is used to enhance maintenance performance of the throttle body. Before using it, cut off the protrusion for positioning bands at the cabjoint.

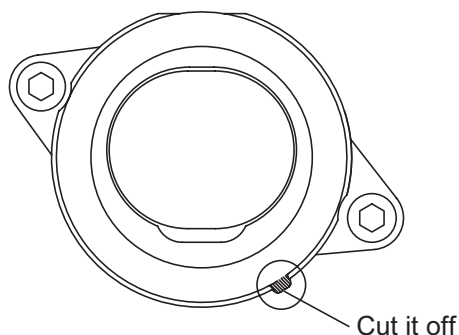

The part has a collar to prevent over-tightening. In normal cases, the part will not be tightened till it reaches to the collar. Just manually tighten it.

Make sure to put a new band through a M4 x 0.7 tap before using it.

15. Air Funnel Set (BN6-1440B-70) for SS

Parts List

No.	PART No.	PART NAME	Q'TY	REMARKS
1	BN6-14479-70	FUNNEL	1	
2	BN6-14469-70	FUNNEL, 1	1	
3	BN6-1446C-70	FUNNEL, 2	1	

Installation

1. Remove the STD funnel.

Refer to the following images and use the removed bolts and levers to fix the KIT funnel.



BN6-14469-70 FUNNEL,1

BN6-1446C-70 FUNNEL,2



BN6-14479-70FUNNEL front side



BN6-14479-70FUNNEL rear side

2. Fit the part to the cutouts and combine the funnel parts.



3. Attach the funnel to the air box.



YCC-I

You can use the YCC-I system with the kit funnel.

You can control the operation timing by using the YMS software packed together with the kit ECU.

You can also control the STD funnel by using the YMS software.

TIP

The STD seal rubber is not used at the bottom surface (face to the primary funnel) of the secondary funnel.

Do not use the camshaft, valve spring, ECU, air funnel and wire harness except for the following combinations.

PARTS COMBINATION TABLE

MODEL	CAMSHAFT(IN)	CAMSHAFT(EX)	VALVE SPRING	AIR FUNNEL SET	ECU	WIRE HARNESS SET
2008	2C0-12171-71	2C0-12181-71	2C0-A2110-70	2C0-8591A-80	2C0-8591A-80 2C0-8591A-90 2C0-8591A-91	13S-F82590-70 13S-F82590-71
2009				MGC-A300908-00		
2010	2C0-12171-72					
2011	2C0-12171-73			MGC-A300908-10 (MGC-A300912-00)	2C0-8591A-92 2C0-8591A-93 2C0-8591A-94	
2012						
2013						
2014						
2015						
2016						

FOR SS

MODEL	CAMSHAFT(IN)	CAMSHAFT(EX)	VALVE SPRING	AIR FUNNEL SET	ECU	WIRE HARNESS SET
2017 2018 2019 2020 2021 2022 2023	2C0-12171-73	2C0-12181-71	2C0-A2110-70	BN6-1440B-70 MGC-A300908-10 with MGC-A300912-00	BN6-8591A-70 BN6-8591A-71	BN6-F2590-70

FOR STK

MODEL	SHAFT CAM1 (INT)	SHAFT CAM 2 (EXT)	VALVE SPRING	AIR FUNNEL SET	ECU	WIRE HARNESS SET
2017 2018 2019 2020 2021 2022 2023	-	-	-	Use with standard air funnel.	BN6-8591A-A0 BN6-8591A-A1 BN6-8591A-A2 BN6-8591A-G0 BN6-8591A-B0 BN6-8591A-B1	BN6-F2590-70
2017 2018 2019 2020 2021 2022 2023	-	-	-	BN6-1440B-80	BN6-8591A-A2 BN6-8591A-B1	

*No other combination is allowed to use.

16. Air Funnel Set (BN6-1440B-80) for STK

Parts List

No.	PART No.	PART NAME	Q'TY	REMARKS
1	13S-14469-10	FUNNEL,1	1	Funnel height:About 46mm
2	13S-1446C-10	FUNNEL,2	1	Funnel height:About 46mm
3	13S-14479-10	FUNNEL	2	Stamp:13S-10
4	13S-14490-10	SHAFT ASSY	1	Rod shape:Straight

Acceleration characteristics change by installing this Air Funnel Set.

Installation

1. Remove the STD funnel and the SHAFT ASSY.

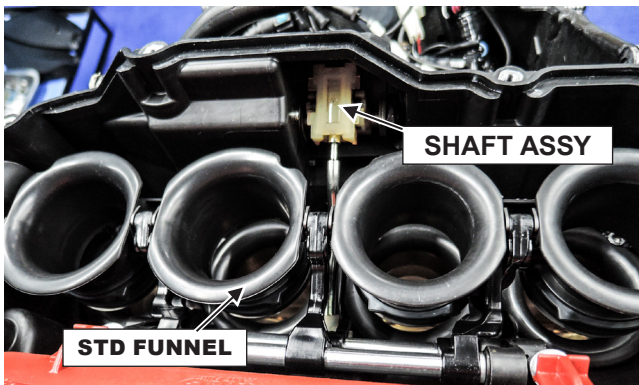

2. Remove the below parts from the STD funnel.

- (1) LEVER,1
- (2) LEVER,2
- (3) BUSH,1
- (4) BUSH,2
- (5) COLLAR
- (6) GROMMET
- (7) RUBBER SEAL



3. Install the parts removed from the STD funnel to the kit funnel.

- Install the BUSH,1 (1 piece) to the center of LEVER,2.

TIP

Align the cut out positions of the BUSH,1 and the LEVER,2.

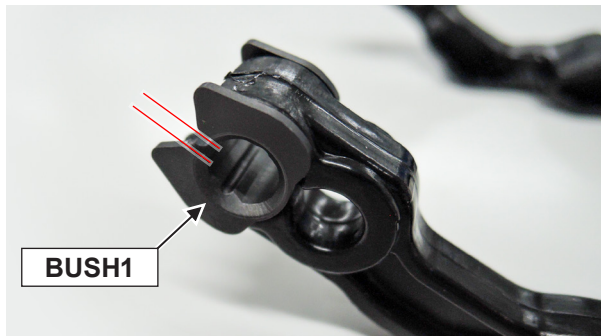

- Install the BUSH,1 (4 pieces) and the RUBBER SEAL to the FUNNEL.

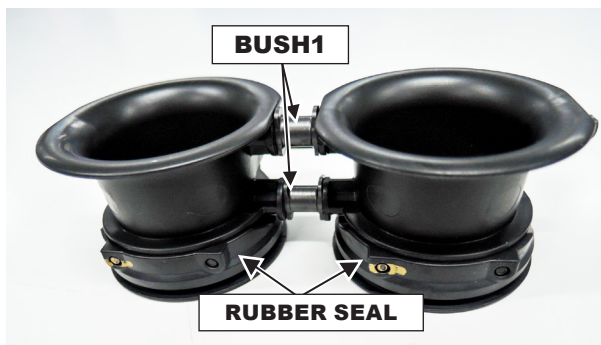

- Install the BUSH,2 (4 pieces) to the FUNNEL,1 and the FUNNEL,2.

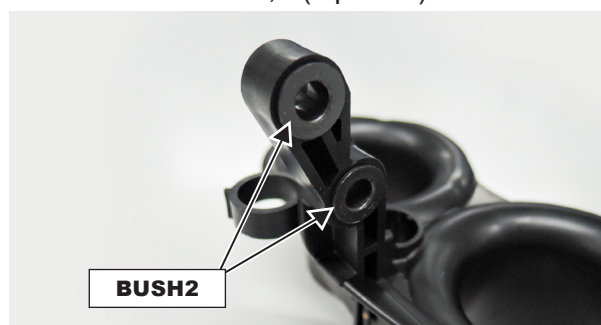

- Install the LEVER,1 and the LEVER,2 to the FUNNEL.



- Install the FUNNEL,1 and the FUNNEL,2.
- Install the COLLAR and the GROMMET to the FUNNEL,1 and the FUNNEL,2.

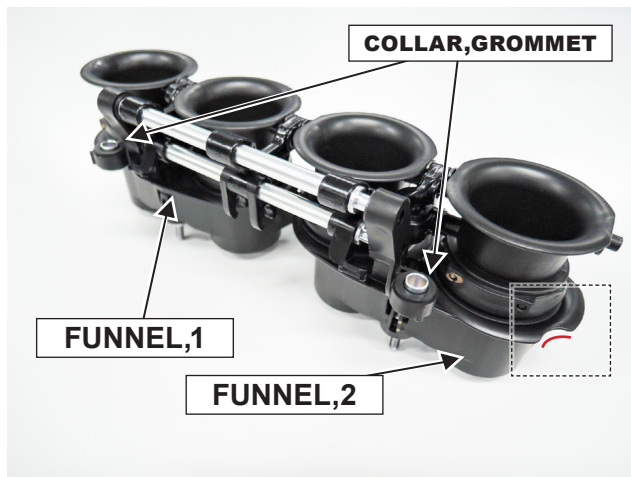

TIP

Align the cut out position of the FUNNEL,2 according to the figure.

4. Install the kit funnel to the air filter case.

5. Install the SHAFT ASSY.

YCC-I

You can use the YCC-I system with the kit funnel.

You can control the operation timing by using the YMS software packed together with the kit ECU.

You can also control the STD funnel by using the YMS software.

PARTS COMBINATION TABLE

MODEL	CAMSHAFT(IN)	CAMSHAFT(EX)	VALVE SPRING	AIR FUNNEL SET	ECU	WIRE HARNESS SET
2008	2C0-12171-71	2C0-12181-71	2C0-A2110-70	2C0-8591A-80	2C0-8591A-80 2C0-8591A-90 2C0-8591A-91	13S-F82590-70 13S-F82590-71
2009				MGC-A300908-00		
2010	2C0-12171-72					
2011	2C0-12171-73			MGC-A300908-10 (MGC-A300912-00)	2C0-8591A-92 2C0-8591A-93 2C0-8591A-94	
2012						
2013						
2014						
2015						
2016						

FOR SS

MODEL	CAMSHAFT(IN)	CAMSHAFT(EX)	VALVE SPRING	AIR FUNNEL SET	ECU	WIRE HARNESS SET
2017 2018 2019 2020 2021 2022 2023	2C0-12171-73	2C0-12181-71	2C0-A2110-70	BN6-1440B-70 MGC-A300908-10 with MGC-A300912-00	BN6-8591A-70 BN6-8591A-71	BN6-F2590-70

FOR STK

MODEL	SHAFT CAM1 (INT)	SHAFT CAM 2 (EXT)	VALVE SPRING	AIR FUNNEL SET	ECU	WIRE HARNESS SET
2017 2018 2019 2020 2021 2022 2023	-	-	-	Use with standard air funnel.	BN6-8591A-A0 BN6-8591A-A1 BN6-8591A-A2 BN6-8591A-G0 BN6-8591A-B0 BN6-8591A-B1	BN6-F2590-70
2017 2018 2019 2020 2021 2022 2023	-	-	-	BN6-1440B-80	BN6-8591A-A2 BN6-8591A-B1	

*No other combination is allowed to use.

17. AIS Plug Set (13S-A4890-70)

This plug set is used when the AIS (Air Induction System), an exhaust gas purification system, is removed.

Parts List

	No.	PART No.	PART NAME	Q'TY	REMARKS
	1	5SL-1482L-70	PLATE, 2	2	
*	2	93608-16M16	PIN, DOWEL	4	
	3	90336-10020	PLUG, TAPER	1	

Installation

1. Remove the hose attached to the cylinder head cover and the air cut-off valve assembly accompanying the hose.
2. Remove the cap fitted to the hose and remove the reed valve and plate from the inside.
3. Install the plate (5SL-1482L-70) in replacement of the cap. Apply liquid gasket to the plate.
4. Remove the cylinder head cover and the four collars fitted to the cover. Install the PIN (93608-16M16).
5. After removing the hose connected to the air cleaner case from the air-cut valve assembly, open the upper case of the air cleaner case and insert the PLUG (90336-10020) into the hole where the hose was connected.

STD

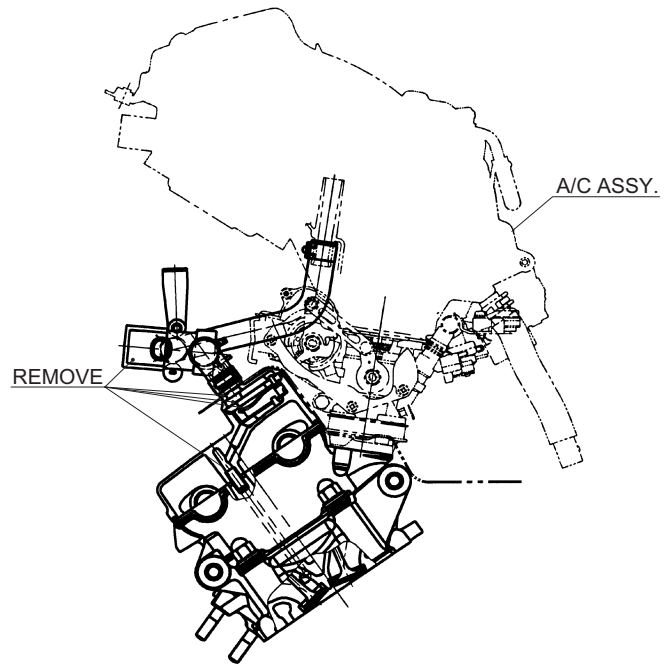

KIT

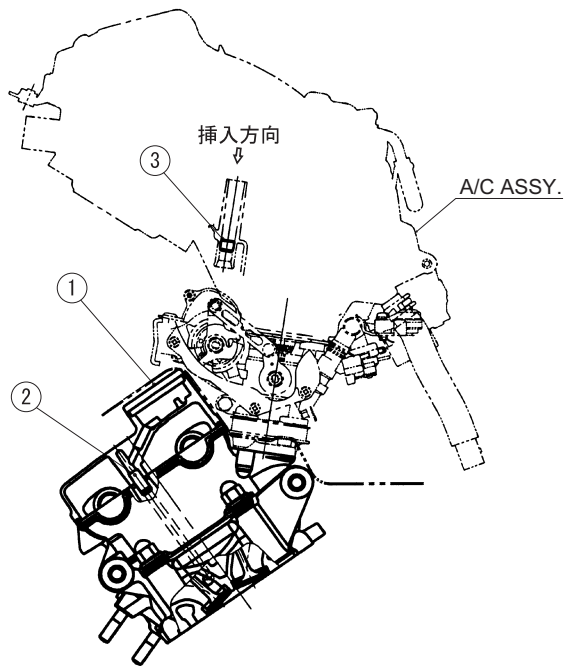

18. Clutch Spring Set (2C0-A6330-70)

Parts List

No.	PART No.	PART NAME	Q'TY	REMARKS
1	2C0-16334-70	SPRING, CLUTCH 2	6	Identifying color: Green

The clutch spring should have a bigger mounting load than standard.

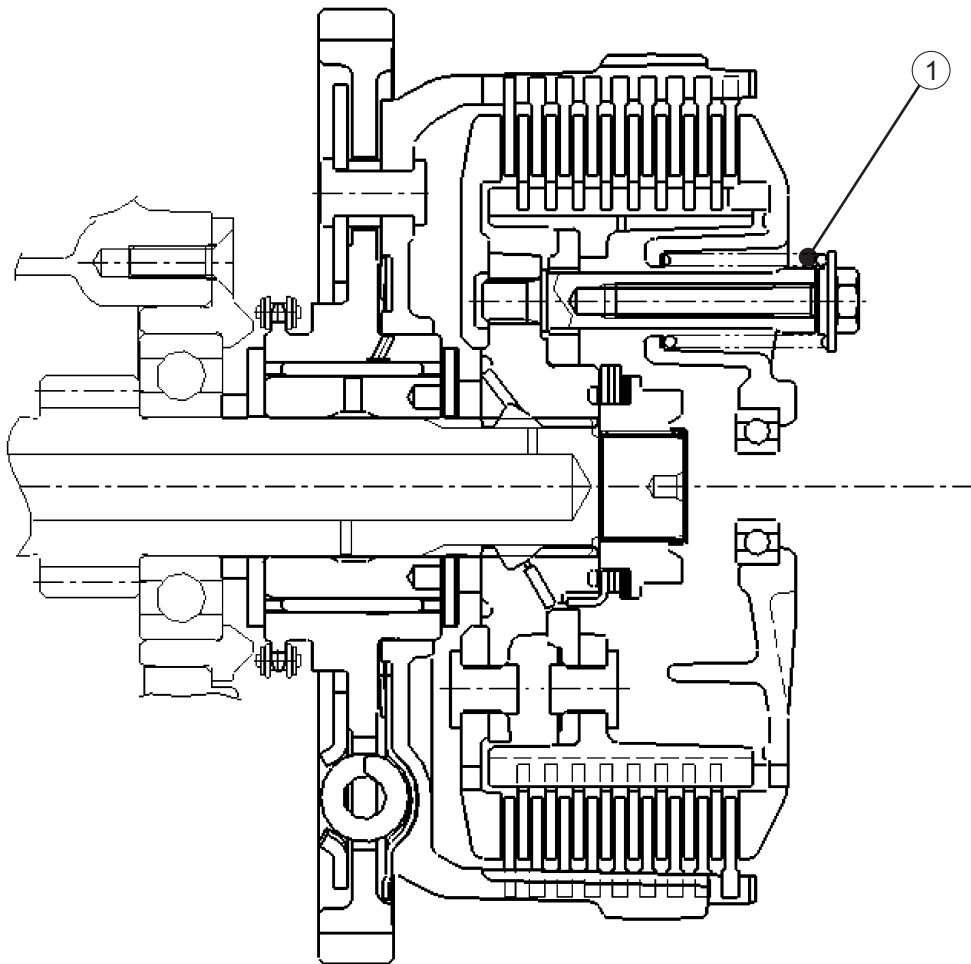

19. Friction Plate Set (2C0-A6321-70)

Parts List

No.	PART No.	PART NAME	Q'TY	REMARKS
1	5EB-16321-72	PLATE, FRICTION 1	9	

Compared to STD, the friction plate enhances durability and operation.

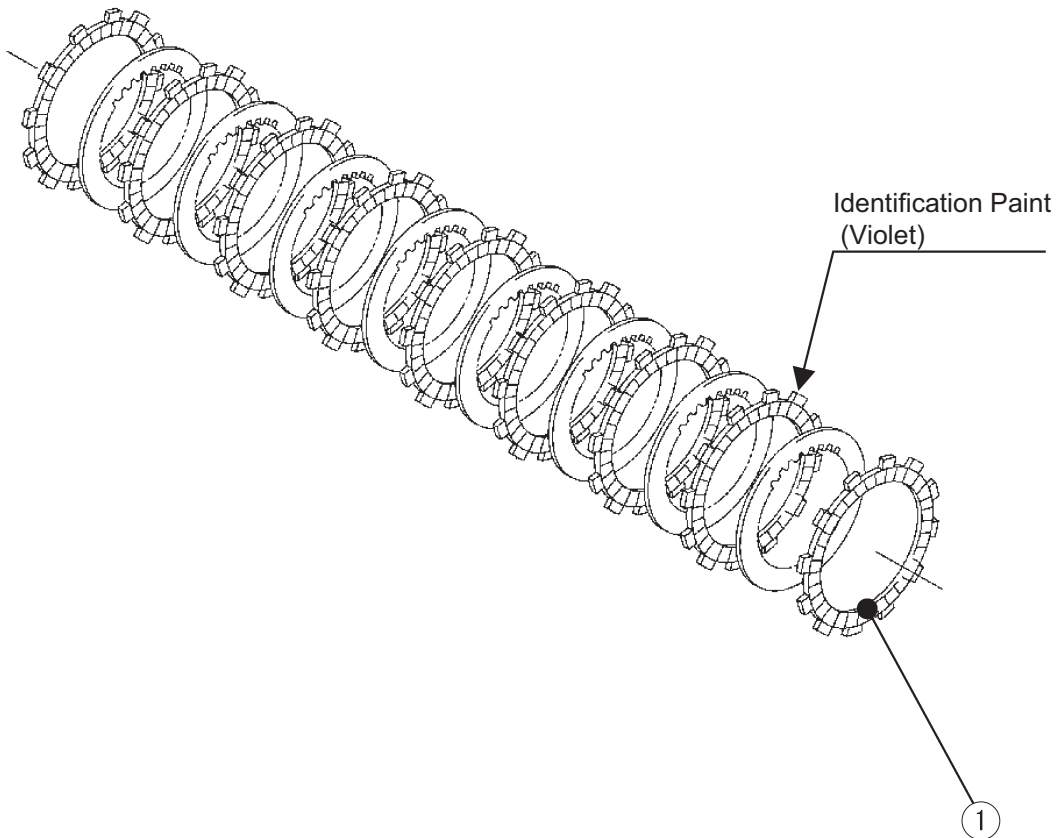

20. Slipper Clutch Setting Set (4B1-A6377-70)

Parts List

No.	PART No.	PART NAME	Q'TY	REMARKS
° 1	4B1-16377-70	NUT, LOCK	1	
° 2	4B1-16391-70	SHIM	3	

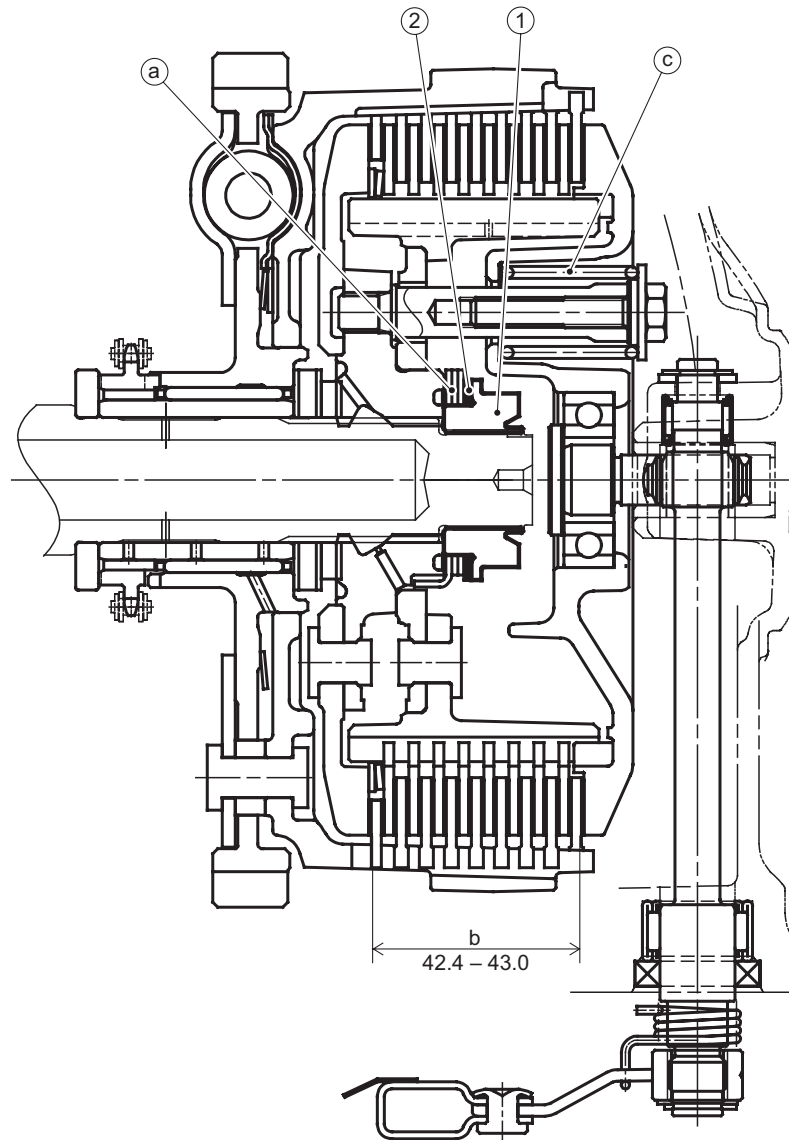

(Setting of back torque limiter of clutch).

A clutch with a back torque limiter mechanism is installed in the YZF-R6 engines. The operation of the back torque limiter can be adjusted through adjusting: ② the number of SHIMs (set up for the kit); ① the number of springs; ③ the whole thickness of the clutch plate; and the strength of ④ spring (set up for the kit) of the slipper clutch setting set.

(Recommended setting method)

To begin with, the dimensions of the clutch are re-set to the standard values. (For details, please refer to the service manual published from YAMAHA MOTOR CO. LTD.



If you attach the slipper clutch setting of kit ① ②, make it the same as the standard setting.

When decreasing the number of SHIMs (standard setting is three) of slipper clutch setting set, the back torque limiter tends to be effective (Engine braking becomes less effective).

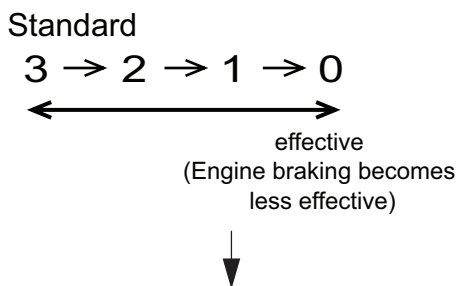

Further, when decreasing the number of ① spring (the number of standard setting is three) to two, the back torque limiter becomes effective (Engine braking becomes less effective).

The clutch spring ③ can be either the kit item or the standard item.

If you mount the clutch spring from the kit, the back torque limiter tends to be less effective (the engine brake becomes stronger).

NOTICE

When decreasing the number of ① spring to two, the caution should be taken to surely use three pieces of SHIMs for the slipper clutch setting set. If its number being less than the above, the less load may be supported so as to exert serious influences on driving. Decreasing the number of ① spring to one is not allowed.

(Clutch plate adjustment)

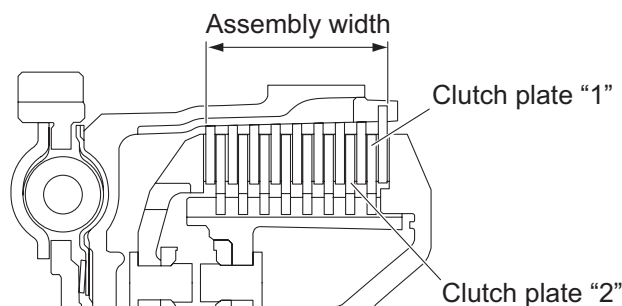

Assembly width adjusted by clutch plate “1” and “2”.

Select the clutch plate from the following table.

Clutch plate “1”		
PART No.	Thickness	
168-16325-00	1.6 mm (0.063 in)	
3J2-16324-00	2.0 mm (0.079 in)	STD
168-16324-00	2.3 mm (0.091 in)	

Clutch plate “2”		
PART No.	Thickness	
3J2-16324-00	2.0 mm (0.079 in)	STD
168-16324-00	2.3 mm (0.091 in)	

TIP

When adjusting the clutch assembly width [by replacing the clutch plate(s)], be sure to replace the clutch plate “1” fast.

After replacing the clutch plate “1”, if specifications cannot be met, replace the clutch plate “2”.

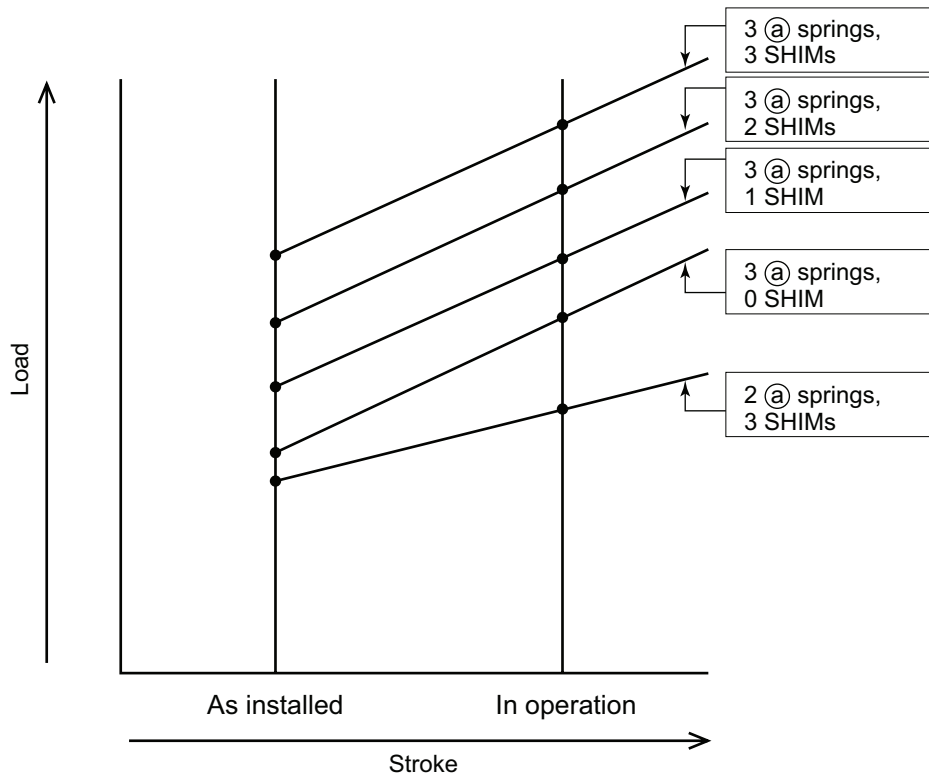

21. Transmission Gear

Parts List

	No.	PART No.	PART NAME	Q'TY	REMARKS
	1	2C0-17411-80-A	AXLE, MAIN	1	A
	1	2C0-17411-90-B	AXLE, MAIN	1	B
*	1	2C0-17411-00	AXLE, MAIN	1	C
*	2	2C0-15163-00	HSG., BEARING	1	
*	3	93306-20562	BRG.	1	
	4	2C0-17151-71-A	GEAR, 5TH PINION	1	A
	4	2C0-17151-80-B	GEAR, 5TH PINION	1	B
	4	2C0-17151-90-C	GEAR, 5TH PINION	1	C
	5	2C0-17131-80-A	GEAR, 3RD PINION	1	A
	5	2C0-17131-71-B	GEAR, 3RD PINION	1	B
	5	2C0-17131-90-C	GEAR, 3RD PINION	1	C
	6	2C0-17161-70-A	GEAR, 6TH PINION	1	A
*	6	2C0-17161-00	GEAR, 6TH PINION	1	B
	6	2C0-17161-90-C	GEAR, 6TH PINION	1	C
	7	2C0-17121-80-A	GEAR, 2ND PINION	1	A
	7	2C0-17121-90-B	GEAR, 2ND PINION	1	B
*	7	2C0-17121-00	GEAR, 2ND PINION	1	C
	8	2C0-17402-70	DRIVE, AXLE ASSY.	1	
*	9	2C0-17421-00	AXLE, DRIVE	1	
*	10	93305-20509	BRG.	1	
*	11	90387-25016	COLLAR	1	
	12	2C0-17221-81-A	GEAR, 2ND WHEEL	1	A
	12	2C0-17221-90-B	GEAR, 2ND WHEEL	1	B
*	12	2C0-17221-00	GEAR, 2ND WHEEL	1	C
	13	2C0-17261-71-A	GEAR, 6TH WHEEL	1	A
	13	2C0-17261-80-B	GEAR, 6TH WHEEL	1	B
	13	2C0-17261-90-C	GEAR, 6TH WHEEL	1	C
	14	2C0-17241-80-A	GEAR, 4TH WHEEL	1	A
	14	2C0-17241-70-B	GEAR, 4TH WHEEL	1	B
	14	2C0-17241-90-C	GEAR, 4TH WHEEL	1	C
	15	2C0-17231-80-A	GEAR, 3RD WHEEL	1	A
	15	2C0-17231-70-B	GEAR, 3RD WHEEL	1	B
	15	2C0-17231-90-C	GEAR, 3RD WHEEL	1	C
	16	2C0-17251-71-A	GEAR, 5TH WHEEL	1	A
	16	2C0-17251-80-B	GEAR, 5TH WHEEL	1	B
	16	2C0-17251-90-C	GEAR, 5TH WHEEL	1	C
	17	2C0-17211-80-A	GEAR, 1ST WHEEL	1	A
	17	2C0-17211-90-B	GEAR, 1ST WHEEL	1	B
*	17	2C0-17211-00	GEAR, 1ST WHEEL	1	C

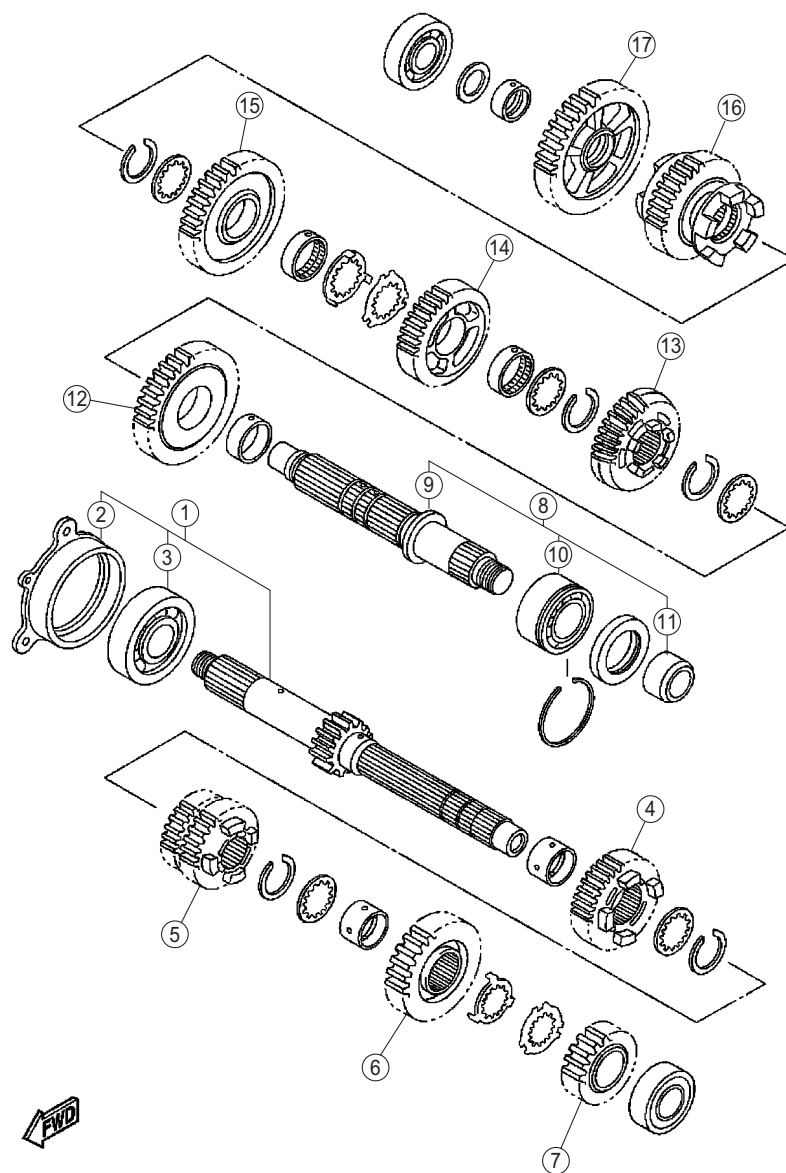

- Gear Ratio

	std	A	B	C
1st	31/12 (2.583)	37/16 (2.313)	42/17 (2.471)	31/12 (2.583)
2nd	32/16 (2.000)	39/21 (1.857)	39/20 (1.950)	32/16 (2.000)
3rd	30/18 (1.667)	36/23 (1.565)	29/18 (1.611)	30/18 (1.667)
4th	26/18 (1.444)	25/18 (1.389)	26/18 (1.444)	28/19 (1.474)
5th	27/21 (1.286)	33/26 (1.269)	30/23 (1.304)	27/20 (1.350)
6th	23/20 (1.150)	25/22 (1.136)	23/20 (1.150)	26/22 (1.182)

NOTICE

- No gear can be used for the kit transmission except for the specified STD gear.
- There is no compatibility with the '06 model transmission set (2C0-A7400-70).

YZF-R6 Mission ratio

GEAR	PLAN	Ratio	Pinion gear			Wheel gear		
			Part number	The number of teeth	Stamp	Part number	The number of teeth	Stamp
1ST	A	2.313	2C0-17411-80-A	16	A	2C0-17211-80-A	37	A
	B	2.471	2C0-17411-90-B	17	B	2C0-17211-90-B	42	B
	C	2.583	2C0-17411-00	12		2C0-17211-00	31	
2ND	A	1.857	2C0-17121-80-A	21	A	2C0-17221-81-A	39	A
	B	1.950	2C0-17121-90-B	20	B	2C0-17221-90-B	39	B
	C	2.000	2C0-17121-00	16		2C0-17221-00	32	
3RD	A	1.565	2C0-17131-80-A	23	A	2C0-17231-80-A	36	A
	B	1.611	2C0-17131-71-B	18	B	2C0-17231-70-B	29	B
	C	1.667	2C0-17131-90-C	18	C	2C0-17231-90-C	30	C
4TH	A	1.389	2C0-17131-80-A	18	A	2C0-17241-80-A	25	A
	B	1.444	2C0-17131-71-B	18	B	2C0-17241-70-B	26	B
	C	1.474	2C0-17131-90-C	19	C	2C0-17241-90-C	28	C
5TH	A	1.269	2C0-17151-71-A	26	A	2C0-17251-71-A	33	A
	B	1.304	2C0-17151-80-B	23	B	2C0-17251-80-B	30	B
	C	1.350	2C0-17151-90-C	20	C	2C0-17251-90-C	27	C
6TH	A	1.136	2C0-17161-70-A	22	A	2C0-17261-71-A	25	A
	B	1.150	2C0-17161-00	20		2C0-17261-80-B	23	B
	C	1.182	2C0-17161-90-C	22	C	2C0-17261-90-C	26	C

Make sure that the pinion and wheel gear are combined for use according to the chart plan.

YZF-R6 Speed List

Engine speed (rpm) 16000
 Tire radius (mm) 315 perimeter (m) 1.979
 Primary reduction ratio 41 85 2.073

GEAR	PLAN	The number of teeth		Ratio												Engine side		Secondary reduction ratio (Sprocket)									
		P	W		16	16	16	15	16	15	16	15	14	16	15	14	15		14	14	14	14	14	Wheel side	52		
1st	A	16	37	2.313	140.9	137.9	134.9	132.1	129.4	129.2	126.8	126.5	124.3	123.8	123.3	121.9	121.3	120.6	118.9	118.1	116.6	115.6	114.3	113.2	111.0	108.8	106.7
	B	17	42	2.471	131.9	129.0	126.3	123.7	121.1	121.0	118.7	118.4	116.4	115.9	115.4	114.1	113.6	112.9	111.3	110.5	109.1	108.2	107.0	106.0	103.9	101.8	99.9
	C	12	31	2.583	126.1	123.4	120.8	118.3	115.8	115.7	113.5	113.2	111.3	110.9	110.4	109.2	108.6	108.0	106.4	105.7	104.3	103.5	102.3	101.4	99.3	97.4	95.5
2nd	A	21	39	1.857	175.5	171.6	168.0	164.5	161.1	160.9	157.9	157.5	154.8	154.2	153.5	151.8	151.1	150.2	148.0	147.0	145.1	143.9	142.4	141.0	138.2	135.5	132.9
	B	20	39	1.950	167.1	163.5	160.0	156.7	153.5	153.3	150.4	150.0	147.4	146.9	146.2	144.6	143.9	143.0	141.0	140.0	138.2	137.1	135.6	134.3	131.6	129.0	126.5
	C	16	32	2.000	162.9	159.4	156.0	152.7	149.6	149.4	146.6	146.2	143.8	143.2	142.6	141.0	140.3	139.5	137.5	136.5	134.8	133.7	132.2	130.9	128.3	125.8	123.4
3rd	A	23	36	1.565	208.2	203.7	199.3	195.2	191.2	190.9	187.4	186.9	183.7	183.0	182.2	180.2	179.2	178.2	175.7	174.4	172.2	170.8	168.9	167.3	163.9	160.7	157.6
	B	18	29	1.611	202.3	197.9	193.7	189.6	185.7	185.5	182.0	181.5	178.5	177.8	177.0	175.0	174.1	173.1	170.7	169.4	167.3	165.9	164.1	162.5	159.3	156.2	153.2
	C	18	30	1.667	195.5	191.3	187.2	183.3	179.6	179.3	176.0	175.5	172.5	171.8	171.1	169.2	168.3	167.4	165.0	163.8	161.7	160.4	158.6	157.1	154.0	151.0	148.0
4th	A	18	25	1.389	234.6	229.5	224.6	220.0	215.5	215.2	211.2	210.6	207.0	206.2	205.3	203.0	202.0	200.8	198.0	196.6	194.1	192.5	190.3	188.5	184.8	181.1	177.7
	B	18	26	1.444	225.6	220.7	216.0	211.5	207.2	206.9	203.0	202.5	199.1	198.3	197.4	195.2	194.2	193.1	190.3	189.0	186.6	185.1	183.0	181.3	177.7	174.2	170.8
	C	19	28	1.474	221.1	216.3	211.7	207.3	203.1	202.8	199.0	198.5	195.1	194.3	193.5	191.4	190.4	189.3	186.6	185.2	182.9	181.4	179.4	177.7	174.1	170.7	167.4
5th	A	26	33	1.269	256.7	251.2	245.8	240.7	235.8	235.5	231.1	230.5	226.5	225.7	224.6	222.2	221.0	219.8	216.6	215.1	212.4	210.6	208.3	206.3	202.2	198.2	194.4
	B	23	30	1.304	249.8	244.4	239.2	234.2	229.4	229.1	224.8	224.2	220.4	219.6	218.6	216.2	215.1	213.8	210.8	209.3	206.7	204.9	202.7	200.8	196.7	192.9	189.2
	C	20	27	1.350	241.4	236.1	231.1	226.3	221.7	221.4	217.2	216.7	213.0	212.1	211.2	208.9	207.8	206.6	203.7	202.2	199.7	198.0	195.8	194.0	190.1	186.4	182.8
6th	A	22	25	1.136	286.8	280.5	274.6	268.8	263.3	263.0	258.1	257.4	253.0	252.0	250.9	248.2	246.9	245.5	242.0	240.2	237.2	235.2	232.6	230.4	225.8	221.4	217.1
	B	20	23	1.150	283.4	277.2	271.3	265.6	260.2	259.9	255.0	254.3	250.0	249.0	247.9	245.2	244.0	242.5	239.1	237.4	234.4	232.4	229.9	227.7	223.1	218.8	214.6
	C	22	26	1.182	275.7	269.7	264.0	258.5	253.2	252.9	248.2	247.5	243.3	242.3	241.3	238.6	237.4	236.0	232.6	231.0	228.1	226.2	223.7	221.6	217.1	212.9	208.8

• Values in the speed table may vary slightly according to tire manufacturer and size.

• Select after referring to the value in the speed table.

22. Mission Maintenance Set (2C0-A7000-70)

Parts List

	No.	PART No.	PART NAME	Q'TY	REMARKS
*	21	90387-250R3	COLLAR	3	
*	22	90209-21332	WASHER	6	
*	23	93440-25186	CIRCLIP	10	
*	24	90387-21003	COLLAR	3	
*	25	90209-22352	WASHER	3	
*	26	90209-21351	WASHER	3	
*	27	90387-28011	COLLAR	3	
*	28	90209-25011	WASHER	9	
*	29	93440-28184	CIRCLIP	15	
*	30	90387-25015	COLLAR	6	
*	31	90214-25004	WASHER, CLAW	3	
*	32	90214-25003	WASHER, CLAW	3	
*	33	90387-21004	COLLAR	3	
*	34	93102-35017	SEAL, OIL	3	
*	35	93440-52014	CIRCLIP	5	
*	36	90201-20278	WASHER, PLAIN	3	
*	37	93306-20464	BRG.	3	
*	38	93306-20464	BRG.	3	

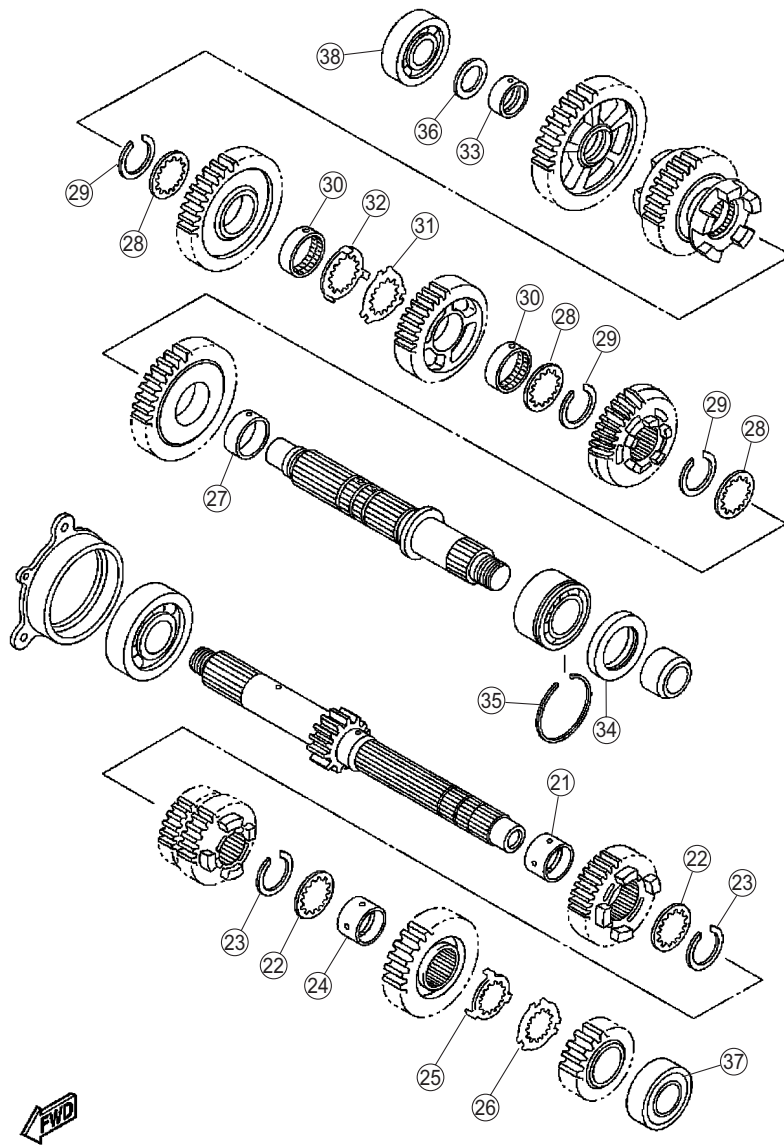

Transmission Assembly

The seal side should face outward (one side seal bearing) and press in the bearing cup all the way into the case until it touches bottom.

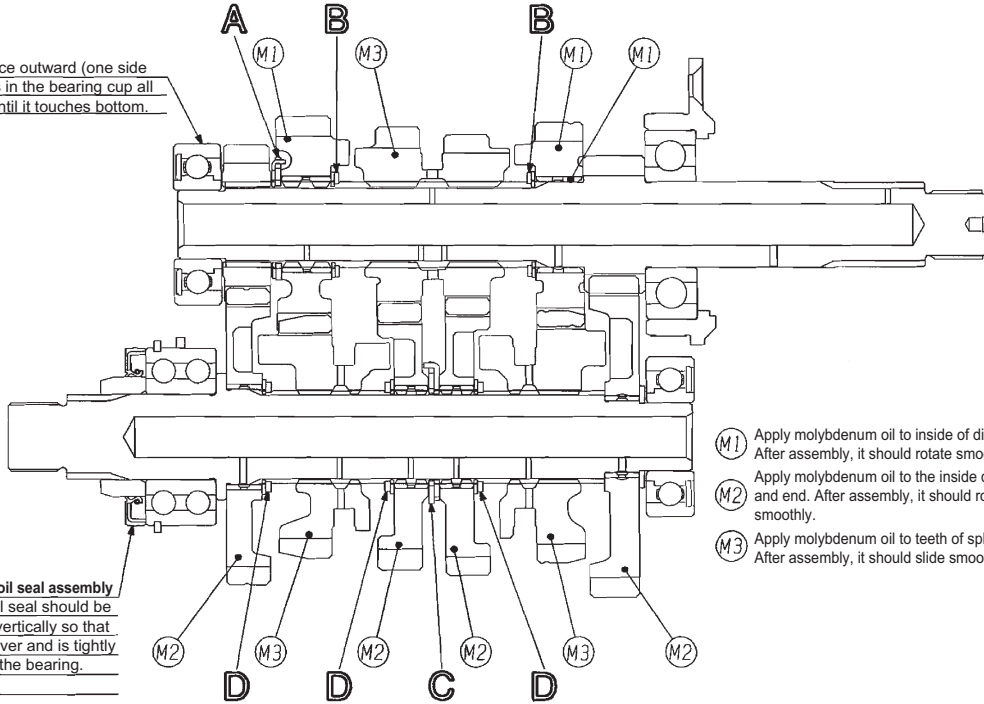

Points to be careful of the oil seal assembly
 The convex part on the oil seal should be put into the case groove vertically so that the oil seal does not fall over and is tightly fit into the bearing cup of the bearing.
 (Apply grease to the lip.)

- (M1) Apply molybdenum oil to inside of diameter. After assembly, it should rotate smoothly.
- (M2) Apply molybdenum oil to the inside diameter and end. After assembly, it should rotate smoothly.
- (M3) Apply molybdenum oil to teeth of spline. After assembly, it should slide smoothly.

TIP

- Always use a new circlip.
- Do not mistake the washer and circlip directions.
 (See drawing below.)

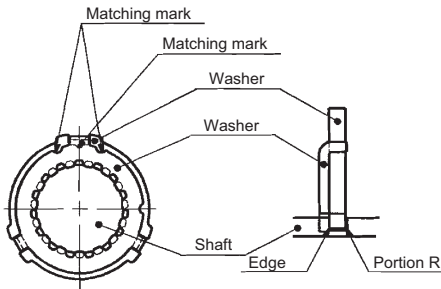

A Detail of installation of washer

Rotate washer so that its teeth meet axle-spline teeth on the axle, and then lock with washer's claw. Assemble washer with putting together their matching mark.

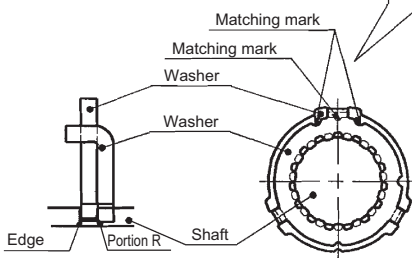

C Detail of installation of washer

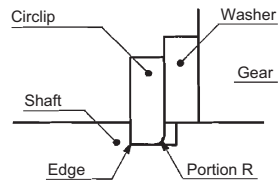

B Detail of installation of circlip

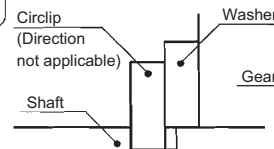

D Detail of installation of circlip

23. Drive Sprocket

Parts List

No.	PART No.	PART NAME	Q'TY	REMARKS
1	2C0-17460-74	SPROCKET, DRIVE	1	14T
2	2C0-17460-75	SPROCKET, DRIVE	1	15T
3	2C0-17460-76	SPROCKET, DRIVE	1	16T

These parts are for 520 chains (STD=525 chain).

Use the nuts for the kit to mount the drive sprocket.

These sprockets are manufactured to be compatible with new and old models.

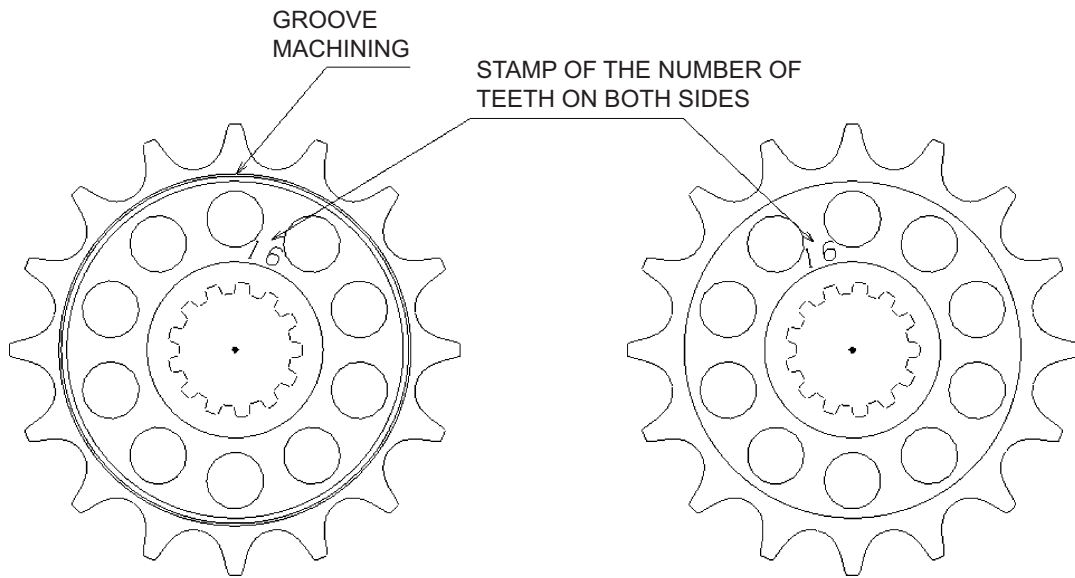

2C0 ('06 and after YZF-R6)

Install with the grooved surface facing outside of the chassis.

5SL ('05 and previous YZF-R6)

Install with the grooved surface facing inside of the chassis.

NOTICE

Take care not to install the sprocket in the wrong direction. If it is installed in the wrong direction, it will cause the misalignment of the drive and rear sprockets, leading to the loss of power.

24. Sprocket Nut Set (2C0-A7463-70)

Parts List

No.	PART No.	PART NAME	Q'TY	REMARKS
1	90179-20005	NUT, SPROCKET	1	
*	90215-21256	WASHER, TONGUED	1	

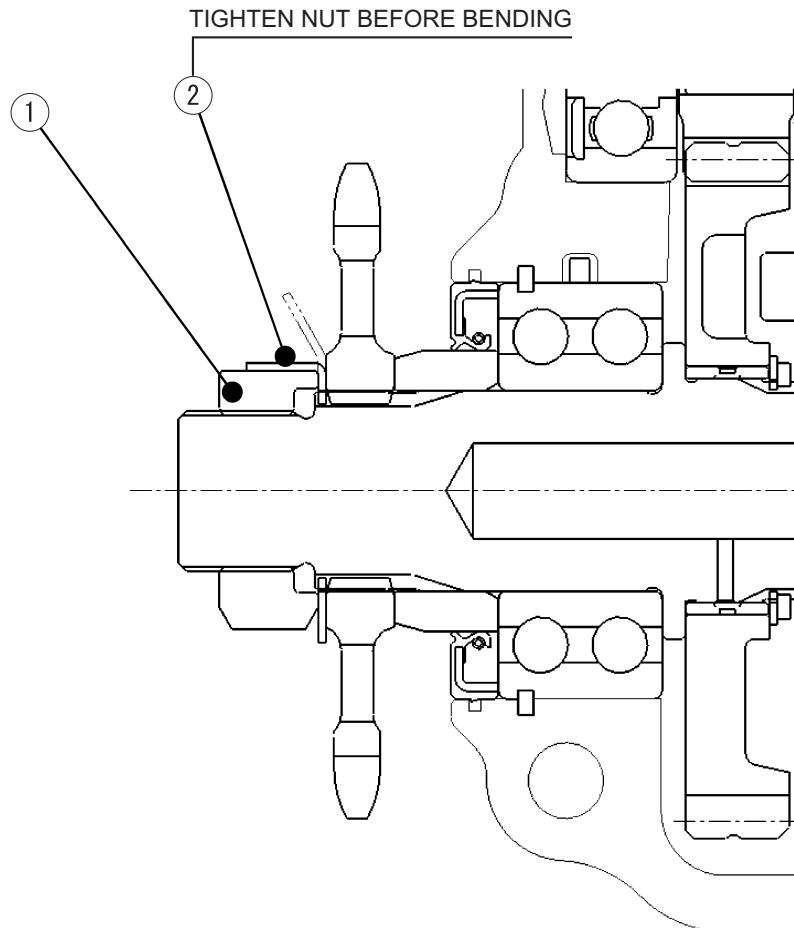

NOTICE

When using this sprocket nut, also use the drive sprocket nut of the kit.

2-3 Vehicle Accessories

25. Oil Catch Tank Set (2C0-C1707-81)

Parts List

No.	PART No.	PART NAME	Q'TY	REMARKS
1	2C0-21707-70	OIL TANK COMP.	1	
*	90450-25037	HOSE CLAMP ASSY.	4	
	13S-15373-70	PIPE, BREATHER	1	
	2C0-15393-70	PIPE, BREATHER 2	1	
*	2C0-2419F-00	BRKT.	1	
*	91317-06020	BOLT, HEX.SOCKET HEAD	2	
*	90480-13018	GROMMET	2	
*	90119-06044	BOLT, HEX. W/WASHER	2	
	2C0-15373-70	PIPE, BREATHER	1	For 2006 and 2007 models

This oil tank has the effective capacity of 540 cc.

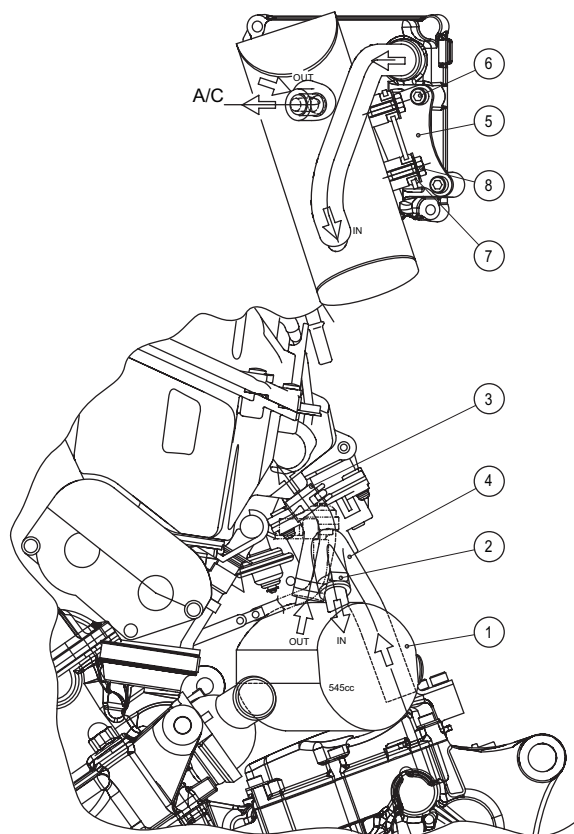

For 2008 and 2009 models

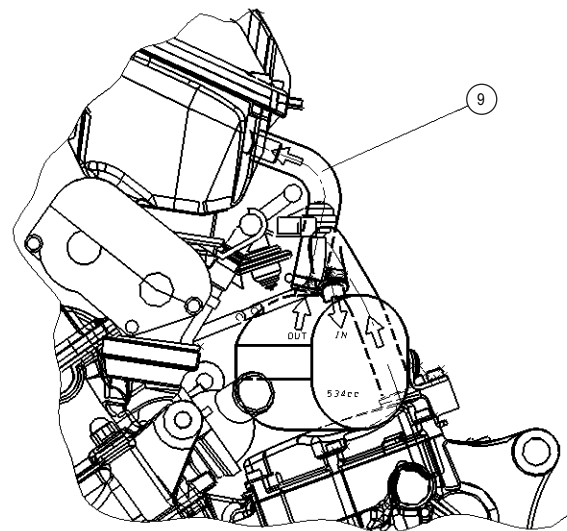

For 2006 and 2007 models

26. Rear Shock Spring

Parts List

No.	PART No.	PART NAME	Q'TY	REMARKS
1	BN6-22222-75	SPRG., Rr. SHOCK	1	108 N/mm Identifying stamp:152.9-56-108
2	BN6-22222-80	SPRG., Rr. SHOCK	1	113 N/mm Identifying stamp:152.9-56-113
3	BN6-22222-85	SPRG., Rr. SHOCK	1	118 N/mm Identifying stamp:152.9-56-118

R6EN181106Rev

- These springs can be used with the standard absorbers.
- There is a stamp on the side of the springs for rate identification.
- The stamp number indicates the length, diameter and rate.
- For spring replacement, see the BN6 STD. Service Manual.
- The spring rate of the standard rear suspension is 103 N/mm.
- The free length is 152.9 mm for STD / KIT springs.

R6180501Rev

27.Front Fork Spring

Parts List

No.	PART No.	PART NAME	Q'TY	REMARKS
1	BN6-23141-75	SPRG., Fr. FORK	1	9.5 N/mm Identifying slits 1
2	BN6-23141-80	SPRG., Fr. FORK	1	10.0 N/mm Identifying slits 2

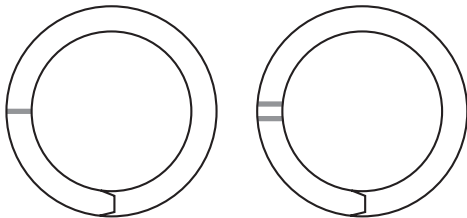

- There are slits at the ends of the spring for rate identification.
- The number of slits indicates the rate as shown above.
- These springs are only for the standard fork of BN6 ('17,'18 models).
- Free length is 219.5 mm for both STD / KIT springs.
- For spring replacement method, BN6 STD. Please refer to service manual.
- The spring rate of STD is 9.0 N / mm

R6180501Rev

TIP

Use Yamaha M1 suspension oil.

References

Front and rear load changes and front and rear suspension movement in different scenarios.

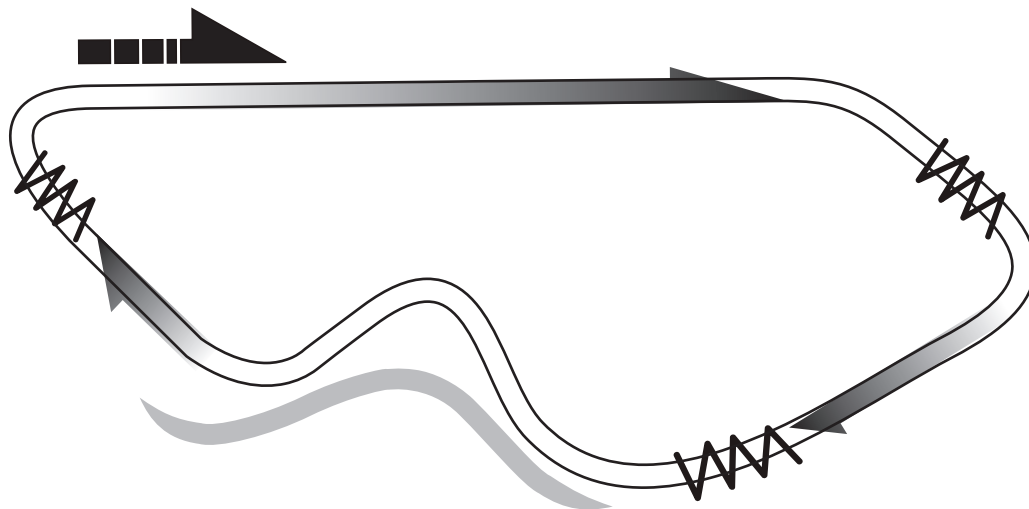

Accelerating

- Load change
The wider the throttle is opened, the more the load is concentrated on the rear.
- Front fork
Reaches nearly maximum extended stroke.
- Rear cushion
Up to 20 to 30 mm stroke displacement, depending on conditions.

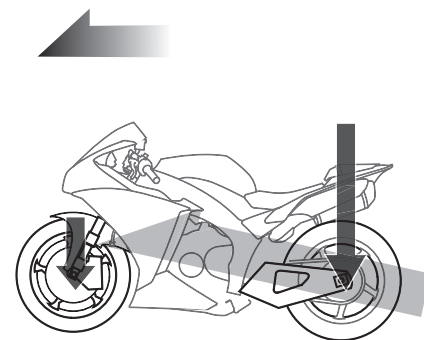

Braking

- Load change
The harder the brake is applied, the more the load is concentrated on the front.
- Front fork
Displaces until stroke has almost bottomed.
- Rear cushion
Reaches nearly maximum extended stroke.

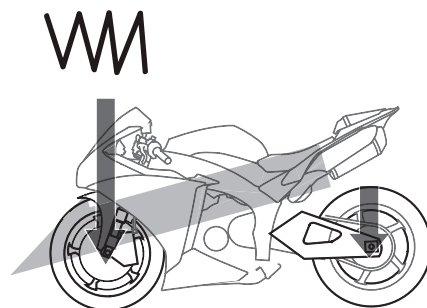

Cornering

- Load change
Increases the load on the front fork and rear cushion on both sides.
- Front fork
Up to 30 to 90 mm stroke displacement depending on the size of the corner.
- Rear cushion
Up to 25 to 40 mm stroke displacement, depending on conditions.

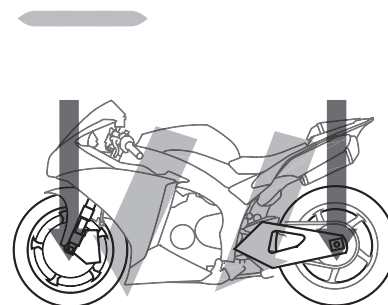

28. Seat Cushion (13S-24713-70)

Parts List

No.	PART No.	PART NAME	Q'TY	REMARKS
1	13S-24713-70	CUSHION SEAT	1	

Anti slip seat.

Cut to any size for use.



FWD

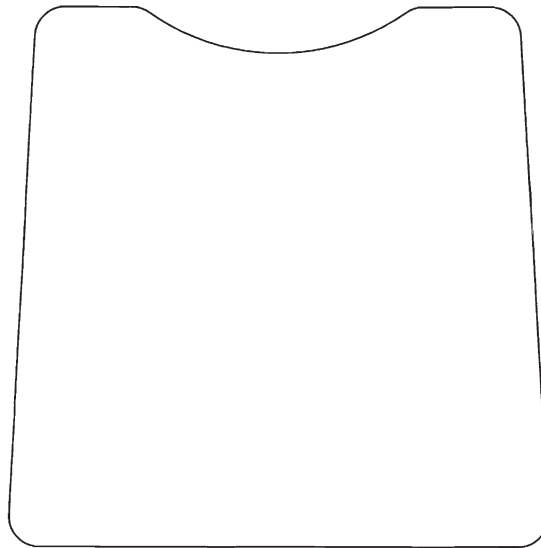

29. Seat Pad (B3L-27741-70)

Parts List

No.	PART No.	PART NAME	Q'TY	REMARKS
1	B3L-27741-70	PAD, SEAT	1	

This seat pad can be cut freely and used as a cushion seat.

Size: 1000mm x 1000mm

Thickness: 10mm



30. Front Spare Wheel Assembly (BN6-25100-70)

Parts List

No	PART No.	PART NAME	Q'TY	REMARKS
* 1	B60-25168-00	WHEEL, CAST	1	
* 2	B60-25117-00	SPACER, BEARING	1	
* 3	93306-00507	BRG.	2	
* 4	93106-31001	SEAL, OIL	2	
* 5	93900-00030	VALVE, RIM	1	
* 6	1SD-2517G-00	ROTOR,SENSOR	1	
* 7	90149-05029	SCREW	5	

*This kit does not include a tire.

This part is an assembly of bearing, spacers, an air valve, and a rotor sensor, in the STD wheel.

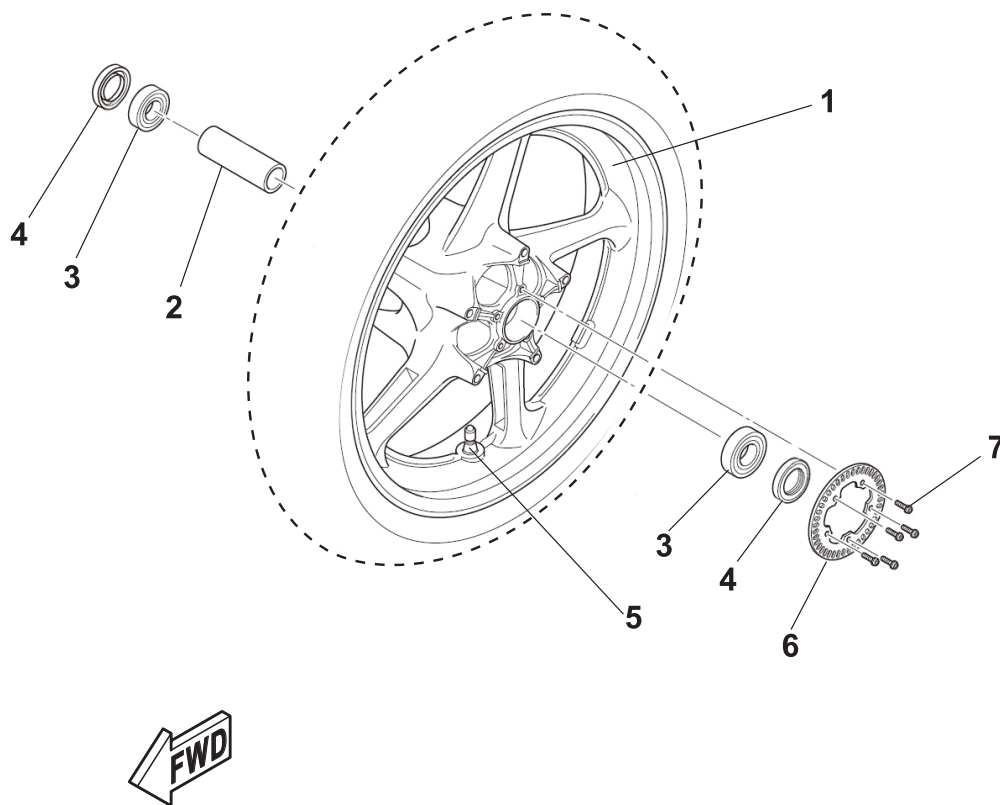

31. Rear Spare Wheel Assembly (BN6-25300-70)

Parts List

No.	PART No.	PART NAME	Q'TY	REMARKS
*	1	BN6-25338-00	WHEEL, CAST	1
*	2	93306-20531	BRG.	1
*	3	BN6-2538E-00	NUT,ADJUSTING	1
*	4	93106-40001	SEAL,OIL	1
*	5	93317-43580	BRG.	1
*	6	5PW-25317-00	SPACER,BEARING	1
*	7	5SL-2582W-00	DISK,BRAKE RR. RH.	1
*	8	90149-08009	SCREW	5
*	9	2PW-2517G-00	ROTOR, SENSOR	1
*	10	90149-05029	SCREW	5
*	11	5SL-25383-00	COLLAR, WHEEL SHAFT	1
*	12	93900-00030	VALVE, RIM	1

*This kit does not include a tire.

This part is an assembly of bearings, spacers,an air valve ,a disk brake, and a rotor sensor, in a STD wheel.

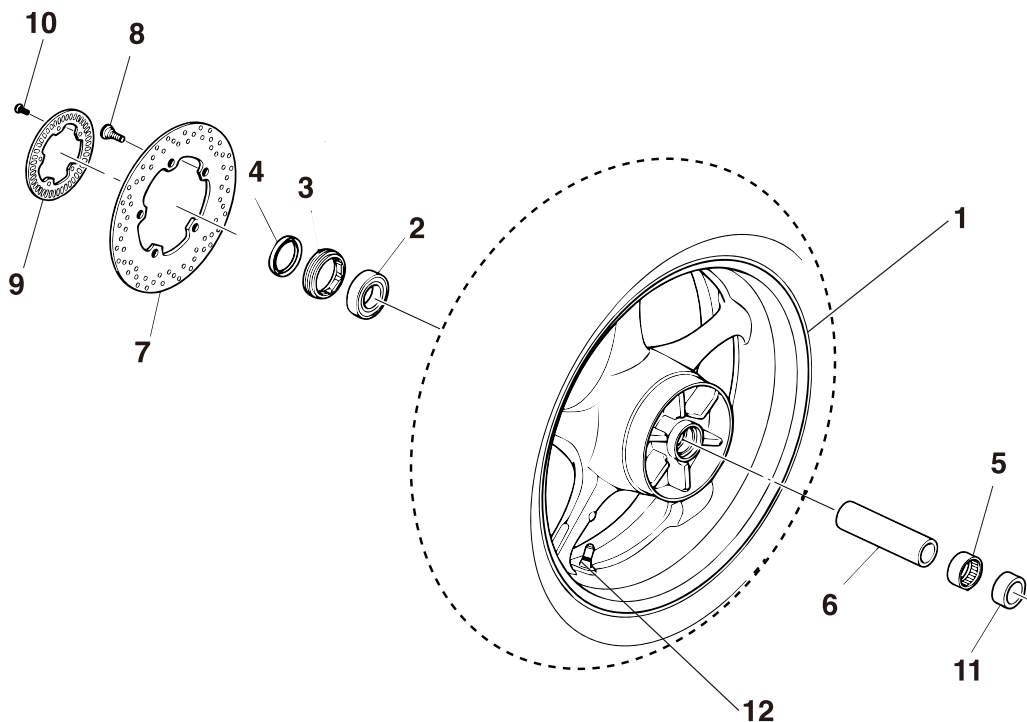

32. Tube Guide (2CR-26243-70)

Parts List

No.	PART No.	PART NAME	Q'TY	REMARKS
1	2CR-26243-70	TUBE, GUIDE	1	

About the Throttle Tube Guide Specifications

As shown below, the operating angle of the throttle grip when the throttle is fully opened is 57.5° as against STD 64.4°.

(Except this part, all other parts (such as a throttle wire) should be STD parts)

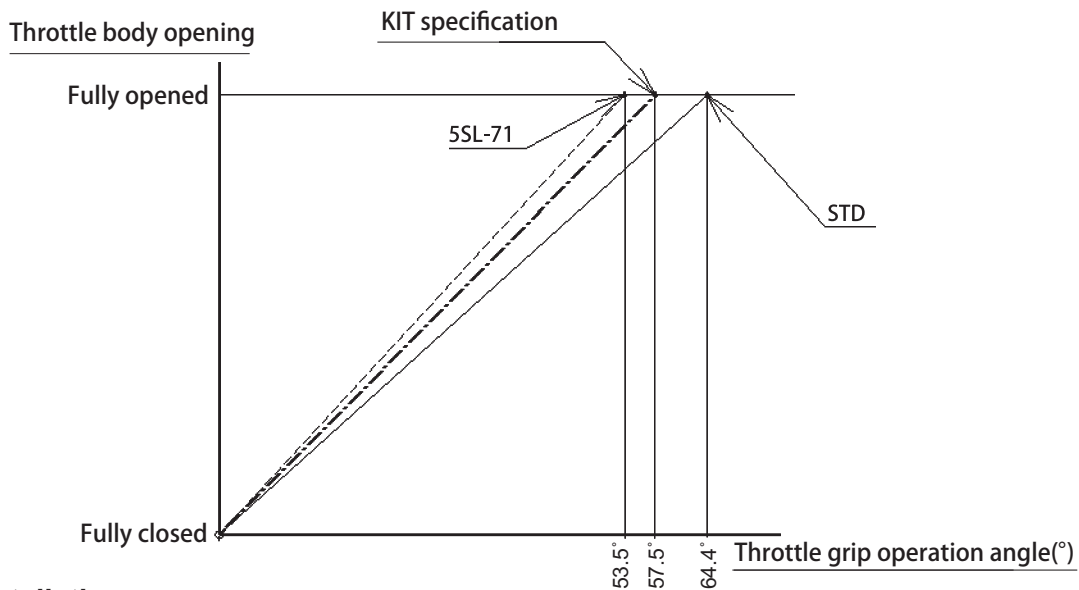

Installation

1. Replace the STD tube guide with the KIT tube guide.
2. As shown below, cut off the stopper inside the pull side cap grip.

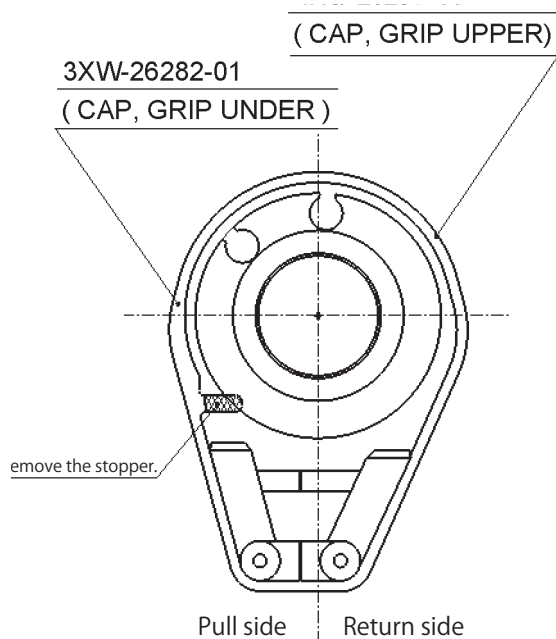

3 Tightening Torque List

Engine

To be tightened	Part No.	Part Name	Screw dia. x pitch	Tightening torque N•m (kgf•m)	Q'ty	Remarks
CAP, CAMSHAFT x HEAD	90105-06027	BOLT, FLANGE	M6 x 1.0	10.0±2 (1.0±0.2)	20	CAM SHAFT SHALL TURN LIGHTLY.
Embedded in HEAD	95612-08625	BOLT, STUD	M8 x 1.25	15.0±3 (1.5±0.3)	8	
Tighten HEAD.	90179-10006	NUT	M10 x 1.25	Tighten in sequence to 25±2 (2.5±0.2) and then tighten in sequence to 42±2 (4.2±0.2).	10	APPLY OIL BOTH TO THREAD AND BEARING SUR- FACE. SEE page 68 FOR DETAILS.
Tighten HEAD.	90176-10075	NUT, CAP	M10 x 1.25	Tighten in sequence to 30±2 (3.0±0.2) and then tighten in sequence to 60±2 (6.0±0.2).	2	APPLY OIL BOTH TO THREAD AND BEARING SUR- FACE. SEE page 68 FOR DETAILS.
Tighten HEAD on side of CAM CHAIN compartment.	90110-06094	BOLT, HEXAGON SOCKET HEAD	M6 x 1.0	12.0±2 (1.2±0.2)	2	WITH WASHER
SPARK PLUG	5FL-1119C-70 13S-1119C-70	PLUG, SPARK	M10S x 1.0	12 – 15 (1.2 – 1.5)	4	SEE page 22 FOR DETAILS.
HEAD COVER x HEAD	90109-066F0	BOLT	M6 x 1.0	10.0±2 (1.0±0.2)	6	
Plug for sand drain hole	90340-18002	PLUG, STRAIGHT SCREW	M18 x 1.5	42±4 (4.3±0.4)	3	APPLY LOCK- ING AGENT (LOCKTITE®).
Check bolt for oil passage	95022-08012	BOLT, FLANGE, SMALL HEAD	M8 x 1.25	15.0±2 (1.5±0.2)	1	
Tighten AI CAP.	90110-06175	BOLT HEXAGON SOCKET HEAD	M6 x 1.0	10.0±2 (1.0±0.2)	4	APPLY LOCK- ING AGENT (LOCKTITE®).
CAMSHAFT x SPROCKET	90105-07004	BOLT, FLANGE	M7 x 1.0	24.0±2 (2.4±0.2)	4	
JOINT, CARBURETOR 1 x HEAD	91312-06016	BOLT, HEXAGON SOCKET HEAD	M6 x 1.0	10.0±2 (1.0±0.2)	8	

Engine

To be tightened	Part No.	Part Name	Screw dia. x pitch	Tightening torque N•m (kgf•m)	Q'ty	Remarks
CON ROD x CAP, CON ROD	2C0-11654-00	BOLT, CON ROD	M7 x 0.75		8	APPLY MOLYB-DENUM DISULFIDE OIL TO THREAD
	2C0-1165A-00	BOLT, CON ROD	M7 x 0.75		8	APPLY MOLYB-DENUM DISULFIDE OIL TO THREAD
	90179-07001	NUT	M7 x 0.75	14.7±1.47 (1.5±0.15) +180°±5°	8	APPLY MOLYB-DENUM DISULFIDE OIL TO BEARING SURFACE
ACM ROTOR x CRANKSHAFT	90105-126A8	BOLT, FLANGE	M12 x 1.25	70±5 (7.0±0.5)	1	DEGREASE TAPERED SUR- FACE. APPLY OIL BOTH TO BOLT BEARING SURFACE AND THREAD AND TO BOTH SIDES OF WASHER. USE MORI- COATED WASHER.
TENSIONER ASSY x CYLINDER	90110-06106	BOLT, HEXAGON SOCKET HEAD	M6 x 1.0	12.0±2 (1.2±0.2)	2	INSTALL TEN- SIONER ASSY.
Install COVER, THERMOSTAT.	91312-06020	BOLT, HEXAGON SOCKET HEAD	M6 x 1.0	12.0±2 (1.2±0.2)	2	
Install JOINT.	90105-06082	BOLT, FLANGE, SMALL HEAD	M6 x 1.0	10.0±2 (1.0±0.2)	2	APPLY LOCK- ING AGENT (LOCKTITE®).
Install WATER PUMP.	90110-06140	BOLT, HEXAGON SOCKET HEAD	M6 x 1.0	12.0±2 (1.2±0.2)	2	APPLY LOCK- ING AGENT (LOCKTITE®).
OIL PUMP ASSY x CRANKCASE 2	95812-06030	BOLT, FLANGE	M6 x 1.0	12.0±2 (1.2±0.2)	2	
OIL PUMP ASSY x CRANKCASE 2	95812-06080	BOLT, FLANGE	M6 x 1.0	12.0±2 (1.2±0.2)	1	
COVER, STRAINER x CRANKCASE 2	90110-06387	BOLT	M6 x 1.0	12.0±2 (1.2±0.2)	13	

Engine

To be tightened	Part No.	Part Name	Screw dia. x pitch	Tightening torque N•m (kgf•m)	Q'ty	Remarks
DRAIN BOLT for COVER, STRAINER	90340-14132	PLUG, STRAIGHT SCREW	M14 x 1.5	43.0±4 (4.3±0.4)	1	DRAIN BOLT
Tighten UNION BOLT for FILTER.	90401-20008	BOLT, UNION	M20 x 1.5	70.0±10 (7.0±1.0)	1	APPLY OIL TO THREAD AND BEARING SUR- FACE.
ELEMENT, OIL FILTER	5GH-13440- 20	OIL CLEANER ASSY	M20 x 1.5	17.0±2 (1.7±0.2)	1	APPLY GREASE TO O-RING.
HOLDER x CRANKCASE 2	90110-06161	BOLT, HEXAGON SOCKET HEAD	M6 x 1.0	12.0±2 (1.2±0.2)	2	APPLY LOCK- ING AGENT (LOCKTITE®).
PIPE, OIL x CRANKCASE 2	90110-06161	BOLT, HEXAGON SOCKET HEAD	M6 x 1.0	12.0±2 (1.2±0.2)	2	APPLY LOCK- ING AGENT (LOCKTITE®).
OIL COOLER x CRANKCASE 2	5EB-12822- 00	BOLT, UNION	M20 x 1.5	63.0±3 (6.3±0.3)	1	APPLY OIL TO THREAD AND BEARING SUR- FACE.
UPPER CASE x CAP CASE ASSY	92012-06020	BOLT, BUTTON HEAD	M6 x 1.0	5.0±0.5 (0.5±0.05)	4	
UPPER CASE x LOWER CASE	98902-05020	SCREW, CROSS RECESS BINDING	M5 x 0.8	2.0±0.5 (0.2±0.05)	10	
ELEMENT x UPPER CASE	98902-05020	SCREW, CROSS RECESS BINDING	M5 x 0.8	2.0±0.5 (0.2±0.05)	1	TIGHTEN AFTER UPPER x LOWER FUNNEL
JOINT, CARBURETOR 1 x THROTTLE	90450-56007	HOSE CLAMP ASSY	M5 x 0.8	2.0 – 2.5 (0.2 – 0.25)	4	CONTACT-FIT COLLAR OR TORQUE CON- TROL
THROTTLE x FUNNEL	90109-05011	BOLT	M5 x 0.8	3.4 – 5 (0.34 – 0.5)	6	
LOWER FILTER CASE x FUNNEL (SUPPORT UNIT)	90159-05035	SCREW, WITH WASHER	M5 x 0.8	2.5±0.5 (0.25±0.05)	2	TIGHTEN AFTER THROTTLE x FUNNEL
Install THROTTLE WIRE	13S-26302- 00	THROT- TLE WIRE ASSY.	M6 x 1.0	3.5 – 5.5 (0.35 – 0.55)	2	

Engine

To be tightened	Part No.	Part Name	Screw dia. x pitch	Tightening torque N•m (kgf•m)	Q'ty	Remarks
NUT, RING x HEAD	90179-08410	NUT	M8 x 1.25	20.0±2 (2.0±0.2)	8	TIGHTEN EXHAUST PIPE & HEAD.
STAY, MUFFLER 1, 2 x MUFFLER	91314-08035	BOLT, HEXAGON SOCKET HEAD	M8 x 1.25	20.0±2 (2.0±0.2)	2	INSTALL EXHAUST PIPE.
STAY, MUFFLER 2 x BRACKET, MUFFLER 1	90105-08054	BOLT, FLANGE (SMALL HEAD)	M8 x 1.25	34.0±4 (3.4±0.4)	1	INSTALL DAMPER.
Tighten BAND, MUFFLER.	91314-06030	BOLT, HEXAGON SOCKET HEAD	M6 x 1.0	10.0±2 (1.0±0.2)	1	
SILENCER x FOOT REST	90110-08099	BOLT, HEXAGON SOCKET HEAD	M8 x 1.25	20.0±2 (2.0±0.2)	1	
Install WIRE PULLEY.	BN6- 1133E-00- BN6-- 1133F-00	WIRE, PULLEY, 1 WIRE, PULLEY, 2	M6 x 1.0	5 – 7 (0.5 – 0.7)	2 2	
Install MUFFLER PROTECTOR.	90111-06071	BOLT, HEXAGON SOCKET BUTTON	M6 x 1.0	8.0±1.5 (0.8±0.15)	1	APPLY LOCK- ING AGENT (LOCKTITE®).
Install MUFFLER PROTECTOR.	90111-06099	BOLT, HEXAGON SOCKET BUTTON	M6 x 1.0	6.5±1.5 (0.65±0.15)	2	APPLY LOCK- ING AGENT (LOCKTITE®).
EXHAUST VALVE SUB ASSY	90179-06063	NUT	M6 x 1.0	6.5±1.5 (0.65±0.15)	1	
CRANKCASE 1 x CRANKCASE 2	90119-08083	BOLT, HEXAGON WITH WASHER	M8 x 1.25	See page 64 for details.	8	APPLY OIL BOTH TO THREAD AND TO BEARING SURFACE.
CRANKCASE 1 x CRANKCASE 2	90119-08084	BOLT, HEXAGON WITH WASHER	M8 x 1.25	See page 64 for details.	2	APPLY OIL BOTH TO THREAD AND TO BEARING SURFACE.
CRANKCASE 1 x CRANKCASE 2	90109-06100	BOLT	M6 x 1.0	10.0±2 (1.0±0.2)	2	APPLY OIL BOTH TO THREAD AND TO BEARING SURFACE.

Engine

To be tightened	Part No.	Part Name	Screw dia. x pitch	Tightening torque N•m (kgf•m)	Q'ty	Remarks
CRANKCASE 1 x CRANKCASE 2	95812-06055	BOLT, FLANGE	M6 x 1.0	10.0±2 (1.0±0.2)	7	APPLY OIL BOTH TO THREAD AND TO BEARING SURFACE.
CRANKCASE 1 x CRANKCASE 2	95812-08065	BOLT, FLANGE	M8 x 1.25	24±2 (2.4±0.2)	2	APPLY OIL BOTH TO THREAD AND TO BEARING SURFACE.
CRANKCASE 1 x CRANKCASE 2	95812-06065	BOLT, FLANGE	M6 x 1.0	10.0±2 (1.0±0.2)	3	APPLY OIL BOTH TO THREAD AND TO BEARING SURFACE.
CRANKCASE 1 x CRANKCASE 2	95812-06045	BOLT, FLANGE	M6 x 1.0	10.0±2 (1.0±0.2)	3	APPLY OIL BOTH TO THREAD AND TO BEARING SURFACE.
CRANKCASE 1 x CRANKCASE 2	95812-06030	BOLT, FLANGE	M6 x 1.0	10.0±2 (1.0±0.2)	1	APPLY OIL BOTH TO THREAD AND TO BEARING SURFACE.
Install COVER, CRANKCASE 1.	90110-06387	BOLT	M6 x 1.0	12.0±2 (1.2±0.2)	7	
Install COVER, CRANKCASE 1.	90110-06390	BOLT	M6 x 1.0	12.0±2 (1.2±0.2)	2	APPLY LOCKING AGENT (LOCKTITE®).
Install COVER, CRANKCASE 2.	90110-06388	BOLT	M6 x 1.0	12.0±2 (1.2±0.2)	7	
Install COVER, CRANKCASE 2.	90110-06389	BOLT, HEXAGON SOCKET HEAD	M6 x 1.0	12.0±2 (1.2±0.2)	2	APPLY LOCKING AGENT (LOCKTITE®).
Install COVER 1.	90109-06396	BOLT	M6 x 1.0	12.0±2 (1.2±0.2)	5	
COVER 1 x HOLDER, CLUTCH	90110-06387	BOLT	M6 x 1.0	12.0±2 (1.2±0.2)	2	
COVER 1 x BOLT	92014-08014	BOLT, BUTTON HEAD	M8 x 1.25	15.0±2 (1.5±0.2)	1	
COVER 1 x PLUG, STRAIGHT	90340-32004	PLUG, STRAIGHT SCREW	M32 x 1.5	CLOSE CONTACT WITH BEARING SURFACE	1	

Engine

To be tightened	Part No.	Part Name	Screw dia. x pitch	Tightening torque N•m (kgf•m)	Q'ty	Remarks
PLATE, BREATHER x C/ C1	90149-06082	SCREW	M6 x 1.0	12.0±2 (1.2±0.2)	3	APPLY LOCK- ING AGENT (LOCKTITE®).
COVER, CRANKCASE 1 x STATOR ASSY	90149-06080	SCREW	M6 x 1.0	10.0±2 (1.0±0.2)	3	APPLY LOCK- ING AGENT (LOCKTITE®).
PLUG WITH COMMUNICATION HOLE x CRANKCASE 1	90149-06082	SCREW	M6 x 1.0	12.0±2 (1.2±0.2)	1	APPLY LOCK- ING AGENT (LOCKTITE®).
Install COVER, CHAIN CASE.	90110-06060	BOLT, HEXAGON SOCKET HEAD	M6 x 1.0	10.0±2 (1.0±0.2)	3	APPLY LOCK- ING AGENT (LOCKTITE®).
Install M GALLERY PLUG.	36Y-15189- 00	PLUG	M16 x 1.5	8.0±2 (0.8±0.2)	2	TAKE CARE NOT TO OVER- TIGHTEN
COVER, CRANKCASE 1 x CLAMP	90149-06082	SCREW	M6 x 1.0	10.0±2 (1.0±0.2)	1	STATOR LEAD APPLY LOCK- ING AGENT (LOCKTITE®).
Install COVER.	90109-06387	BOLT	M6 x 1.0	12.0±2 (1.2±0.2)	5	
Install OIL PIPE (OUTSIDE)	90110-06161	BOLT, HEXAGON SOCKET HEAD	M6 x 1.0	12.0±2 (1.2±0.2)	2	APPLY LOCK- ING AGENT (LOCKTITE®).
CRANKCASE 2 x PICKUP	90110-06168	BOLT, HEXAGON SOCKET HEAD	M6 x 1.0	10.0±2 (1.0±0.2)	2	APPLY LOCK- ING AGENT (LOCKTITE®).
Embedded in CRANKCASE x STUD, EMBEDDED	90116-1002*	BOLT, STUD	M10 x 1.25	(HEIGHT 68.2±1)	10	
Install PRESSURE PLATE.	90159-06024	SCREW, W/W	M6 x 1.0	8.0±2 (0.8±0.2)	6	
BOSS, CLUTCH x MAIN AXLE	4B1-16377- 70	NUT, LOCK	M20 x 1.0	115.0±5 (11.5±0.5)	1	CRIMP AND APPLY OIL BOTH TO THREAD AND BEARING SUR- FACE.
BOSS, PRESSURE PLATE x BOLT, STUD	2C0-16374- 00	BOLT, STUD	M8 x 1.25	25.0±2 (2.5±0.2)	6	APPLY LOCK- ING AGENT (LOCKTITE®).

Engine

To be tightened	Part No.	Part Name	Screw dia. x pitch	Tightening torque N•m (kgf•m)	Q'ty	Remarks
Install SPROCKET, DRIVE.	90179-20005	NUT	M20 x 1.0	85.0±5 (8.5±0.5)	1	WITH LOCK WASHER
HOUSING, BEARING	90151-06024	SCREW, CROSS- RECESSED COUNTER- SUNK	M6 x 1.0	12.0±2 (1.2±0.2)	3	APPLY LOCK- ING AGENT (LOCKTITE®).
Install STOPPER, SHAFT BAR.	90110-06182	BOLT, HEXAGON	M6 x 1.0	10.0±2 (1.0±0.2)	2	APPLY LOCK- ING AGENT (LOCKTITE®).
STOPPER embedded in CRANKCASE	1D7-18127-00	STOPPER, SCREW	M8 x 1.25	22.0±2 (2.2±0.2)	1	APPLY LOCK- ING AGENT (LOCKTITE®).
Install ARM, SHIFT.	95822-06020	BOLT, FLANGE	M6 x 1.0	10.0±2 (1.0±0.2)	1	CHECK FOR SERRATION TIGHTENING UP.
Install ROTOR, PICKUP.	90105-08113	BOLT, FLANGE	M8 x 1.25	35.0±5 (3.5±0.5)	1	
Install STARTER MOTOR.	90105-06083	BOLT, FLANGE (SMALL HEAD)	M6 x 1.0	10.0±2 (1.0±0.2)	2	
NEUTRAL SWITCH ASSY	3GB-82540- 01	NEUTRAL S/W ASSY	M10 x 1.25	17.0±2 (1.7±0.2)	1	OVERTIGHTEN- ING LEADS TO DAMAGE.
Install OIL LEVEL SENSOR.	95022-06016	BOLT, FLANGE (SMALL HEAD)	M6 x 1.0	10.0±2 (1.0±0.2)	2	APPLY GREASE TO O-RING.
CAM SENSOR x COVER H/C	90110-06175	BOLT, HEXAGON SOCKET HEAD	M6 x 1.0	7.5±1.5 (0.75±0.15)	1	APPLY LOCK- ING AGENT (LOCKTITE®).
Install O2 SENSOR.	13S-8592A- 00	O2 SEN- SOR	M18 x 1.5	45.0±5 (4.5±0.5)	1	
Install THERMO- SENSOR.	5YP-85790- 00	THERMO- SENSOR ASSY	M12 x 1.5	17.6±2 (1.8±0.2)	1	
Install O2 SENSOR.	2CR-8592A-10 BN6-8592A-00	O2 SEN- SOR	M12×1.25	23±2(2.3±0.2)	1 1	
Install SENSOR, GEAR POSITION	90149-05037	SCREW	M5×0.8	3~5(0.3±0.5)	2	APPLY LOCK- ING AGENT (LOCKTITE®).

Body

To be tightened	Part No.	Part Name	Screw dia. x pitch	Tightening torque N•m (kgf•m)	Q'ty	Remarks
HANDLE, CROWN & OUTER TUBE	91314-08030	BOLT, HEXAGON SOCKET HEAD	M8 x 1.25	28-35 (2.8 – 3.5)	2	
HANDLE, CROWN & STEERING SHAFT	90170-28419	NUT, HEXAGON	M28 x 1.0	100 – 125 (10.2 – 12.7)	1	
HANDLE & OUTER TUBE	91314-08030	BOLT, HEXAGON SOCKET HEAD	M8 x 1.25	28 – 35 (2.8 – 3.6)	2	
STEERING SHAFT and RING NUT	90179-30691	NUT	M30 x 1.0	12 – 15 (1.2 – 1.5)	1	
OUTER TUBE & UNDER BRACKET	91314-08030	BOLT, HEXAGON SOCKET HEAD	M8 x 1.25	20 – 25 (2.0 – 2.5)	4	
E/G BRACKET, FRONT	95024-10040	BOLT, FLANGE (SMALL HEAD)	M10 x 1.25	35 – 45 (3.6 – 4.6)	4	
E/G BRACKET, REAR UPPER	90105-12228	BOLT, FLANGE	M12 x 1.25		1	
	90179-12004	NUT	M12 x 1.25	58 – 70 (5.9 – 7.1)	1	
E/G BRACKET, REAR UNDER	90105-12228	BOLT, FLANGE	M12 x 1.25		1	
	90179-12004	NUT	M12 x 1.25	58 – 70 (5.9 – 7.1)	1	
MAIN FRAME & REAR FRAME	90149-10002	SCREW	M10 x 1.25	33 – 40 (3.3 – 4.1)	4	
PIVOT SHAFT & FRAME	2C0-22141- 10	SHAFT, PIVOT	M32 x 1.5	12 – 19 (12.2 – 1.9)	1	
ARM, RELAY 1 & FRAME	90105-10211	BOLT	M10 x 1.25		1	SCREW IN FROM THE LEFT SIDE
	95602-10200	NUT, U FLANGE	M10 x 1.25	31 – 49 (3.2 – 5)	1	
ARM, RELAY 1 & ARM 1	90105-12081	BOLT	M12 x 1.25		1	SCREW IN FROM THE LEFT SIDE
	90185-12011	NUT, SELF LOCKING	M12 x 1.25	31 – 49 (3.2 – 5)	1	

Body

To be tightened	Part No.	Part Name	Screw dia. x pitch	Tightening torque N•m (kgf•m)	Q'ty	Remarks
ARM 1 & REAR ARM	90105-12081	BOLT	M12 x 1.25		1	SCREW IN FROM THE LEFT SIDE
	90185-12011	NUT, SELF LOCKING	M12 x 1.25	31 – 49 (3.2 – 5)	1	
REAR CUSHION & ARM, RELAY 1	90105-12082	BOLT	M12 x 1.25		1	SCREW IN FROM THE LEFT SIDE
	90185-12011	NUT, SELF LOCKING	M12 x 1.25	31 – 49 (3.2 – 5)	1	
SHAFT, PIVOT & LOCK NUT	2C0-22252-00	NUT 2	M32 x 1.5	75 – 115 (7.6 – 11.7)	1	
SHAFT, PIVOT & U NUT	90185-22009	NUT SELF LOCKING	M22 x 1.5	55 – 85 (5.6 – 8.7)	1	
FUEL PUMP & FUEL TANK	90119-05015	BOLT, HEXAGON WITH WASHER	M5 x 0.8	3 – 5 (0.3 – 0.5)	4	
FRONT STAY for FUEL TANK & FRAME	90110-06233	BOLT, HEXAGON SOCKET HEAD	M6 x 1.0	3 – 5 (0.3 – 0.5)	1	
Mid portion of FUEL TANK & STAY	90119-06262	BOLT, HEXAGON WITH WASHER	M6 x 1.0	7 – 10 (0.7 – 1.0)	2	
BRACKET, TANK (rear) & FUEL TANK	95812-06090	BOLT, FLANGE	M6 x 1.0	3 – 5 (0.3 – 0.5)	1	
	95702-06500	NUT, FLANGE	M6 x 1.0		1	
FRONT WHEEL SHAFT & FR FORK	90179-24004	NUT	M24 x1.0	100– 130 (10 – 13)	1	
REAR WHEEL SHAFT & NUT	90185-24008	NUT, SELF LOCKING	M24 x 1.5	90 – 130 (9.2 – 13.3)	1	
FR CALIPER & FR FORK	90105-10397	BOLT, UNION	M10 x 1.25	30 – 40 (3.1 – 4.1)	4	
DISC BRAKE & FR WHEEL	90149-06043	SCREW	M6 x 1.0	14 – 19 (1.4 – 1.9)	10	APPLY LOCK- ING AGENT (LOCKTITE®).
DISC BRAKE & RR WHEEL	90149-08009	SCREW	M8 x 1.25	23 – 37 (2.3 – 3.8)	5	APPLY LOCK- ING AGENT (LOCKTITE®).
REAR WHEEL SPROCKET & CLUTCH HUB	90185-10011	NUT, SELF LOCKING	M10 x 1.25	90 – 109 (9.2 – 11.1)	6	

Tightening the Cylinder Head

Tightening the Cylinder Head

1. In the sequence 1 to 10, tighten 1 to 7 and 10 to a torque of 25 N•m (2.5 kgf•m) and tighten 8 and 9 to a torque of 30 N•m (3.1 kgf•m).
2. Next, in sequence, tighten 1 to 7 and 10 to a torque of 42 N•m (4.2 kgf•m) and tighten 8 and 9 to a torque of 60.0 N•m (6.1 kgf•m).

TIP

The numbers 1 to 10 show the sequence in which the bolts are tightened.

Apply engine oil to the bolt threads, contact surfaces, and washers.

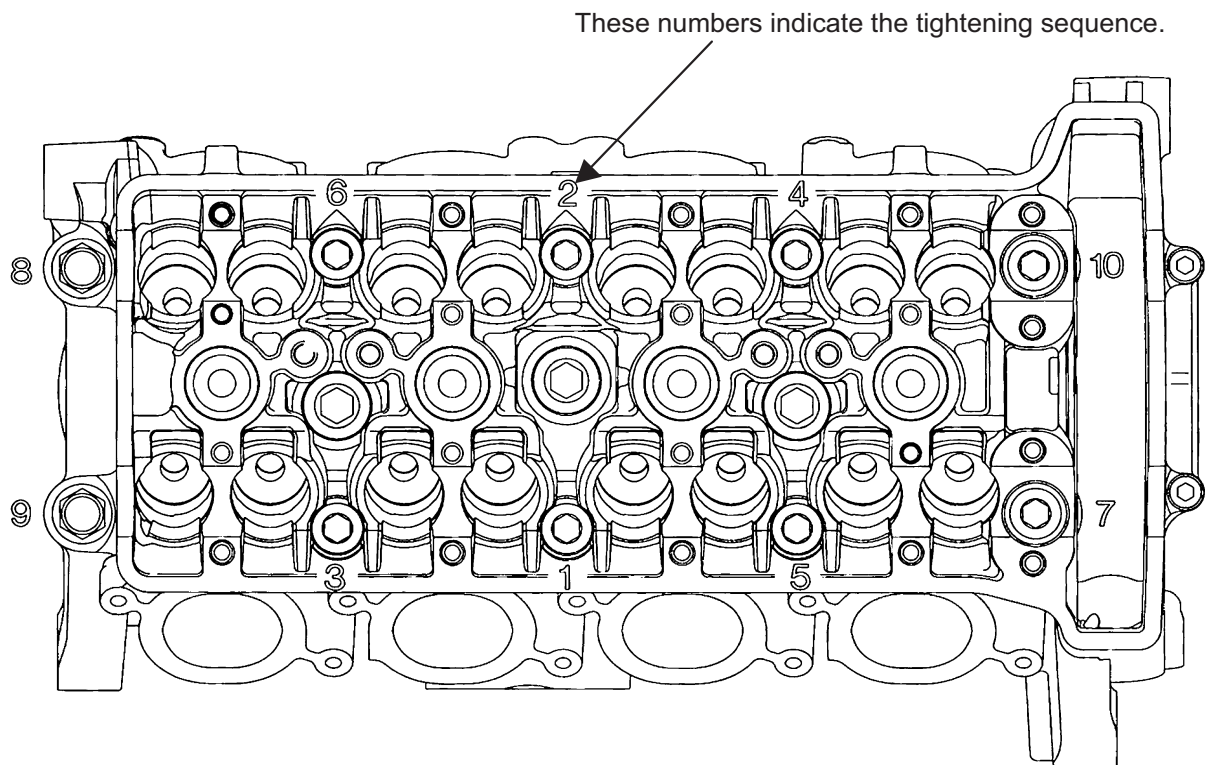

Installing the Crankcase

Tightening the bolts

1. Tighten the bolts in the tightening sequence of 1 to 10 to 20 N•m (2.0 kg•m).
2. After loosening the bolts once in the tightening sequence of 1 to 10, retighten them one by one to 12 N•m (1.2 kg•m).
3. Retighten the bolts in the tightening sequence of 1 to 7 to a turn-of-nut angle of $50^{\circ}\pm 5^{\circ}$.
4. Retighten the bolts in the tightening sequence of 8 and 9 to a turn-of-nut angle of $75^{\circ}\pm 5^{\circ}$.
5. Retighten the bolt in the sequence of 10 to a turn-of-nut angle of $50^{\circ}\pm 5^{\circ}$.
6. Tighten the bolts in the tightening sequence of 11 and 12 to 24 ± 2 N•m (2.4 ± 0.2 kgf•m).
7. Tighten the bolts in the tightening sequence of 13 to 29 to 10 ± 2 N•m (1.0 ± 0.2 kgf•m).

TIP

The numbers 1 to 29 show the sequence in which the bolts are tightened.

Apply engine oil to the bolt threads and both sides of the washers.

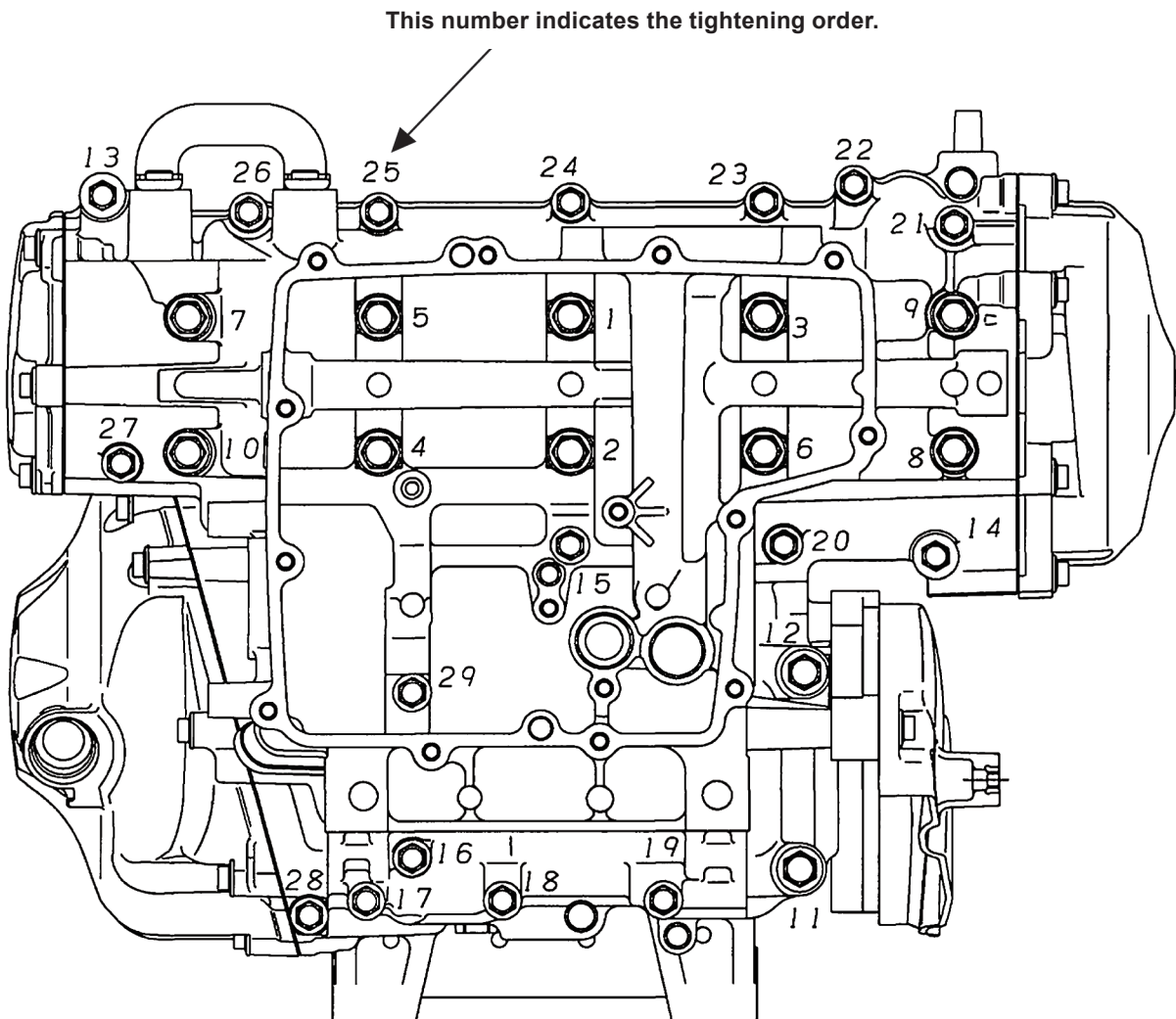

4 YZF-R6 Wiring Diagram

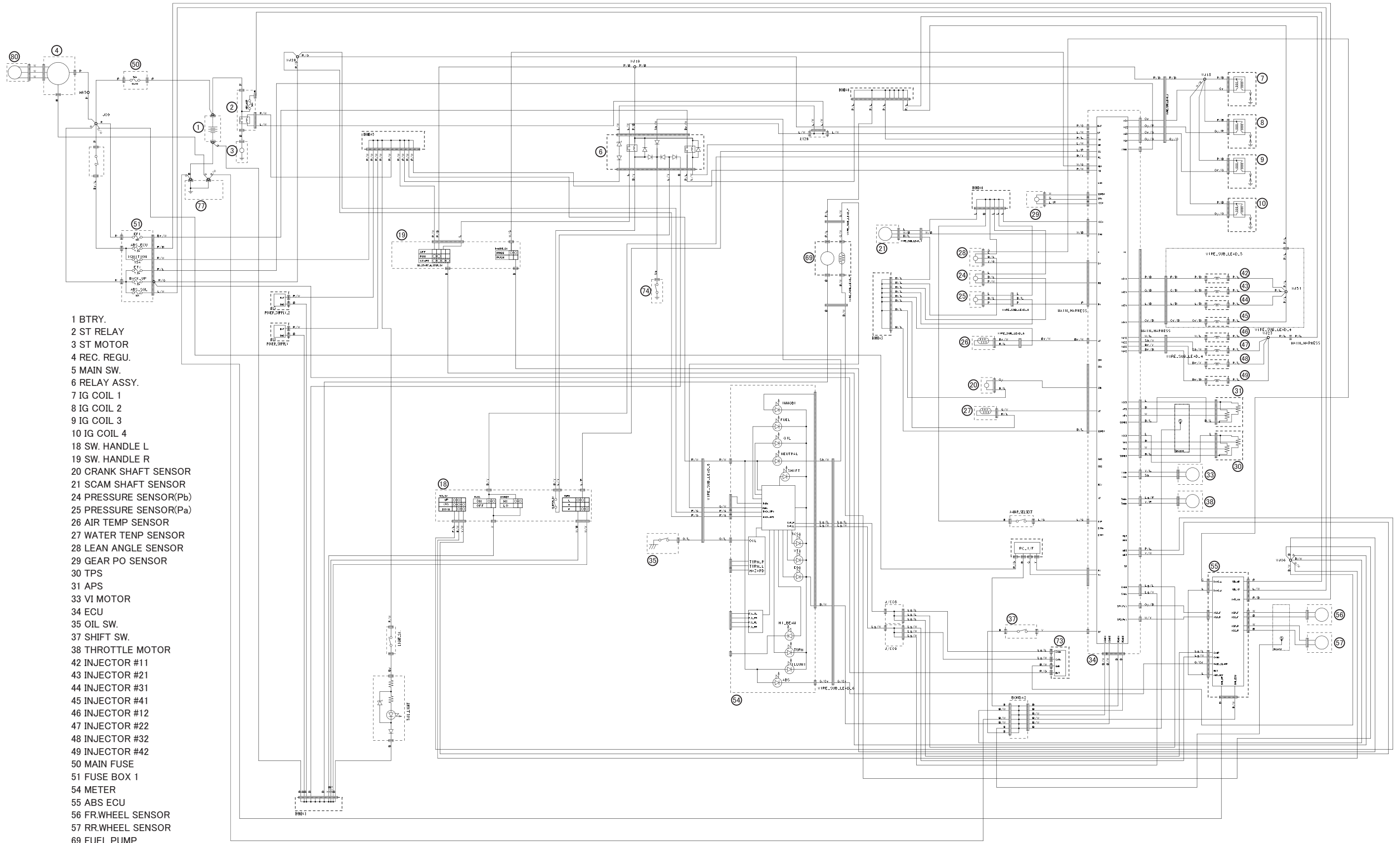

- 1 BTRY.
- 2 ST RELAY
- 3 ST MOTOR
- 4 REC. REGU.
- 5 MAIN SW.
- 6 RELAY ASSY.
- 7 IG COIL 1
- 8 IG COIL 2
- 9 IG COIL 3
- 10 IG COIL 4
- 18 SW. HANDLE L
- 19 SW. HANDLE R
- 20 CRANK SHAFT SENSOR
- 21 SCAM SHAFT SENSOR
- 24 PRESSURE SENSOR(Pb)
- 25 PRESSURE SENSOR(Pa)
- 26 AIR TEMP SENSOR
- 27 WATER TENP SENSOR
- 28 LEAN ANGLE SENSOR
- 29 GEAR PO SENSOR
- 30 TPS
- 31 APS
- 33 VI MOTOR
- 34 ECU
- 35 OIL SW.
- 37 SHIFT SW.
- 38 THROTTLE MOTOR
- 42 INJECTOR #11
- 43 INJECTOR #21
- 44 INJECTOR #31
- 45 INJECTOR #41
- 46 INJECTOR #12
- 47 INJECTOR #22
- 48 INJECTOR #32
- 49 INJECTOR #42
- 50 MAIN FUSE
- 51 FUSE BOX 1
- 54 METER
- 55 ABS ECU
- 56 FR.WHEEL SENSOR
- 57 RR.WHEEL SENSOR
- 69 FUEL PUMP
- 74 NEWTRAL SW.
- 77 EG EARTH
- 80 ACM
- 73 SERVICE TOOL

